

EE Times

For the creators of technology

europa

Car battery in a bottle 17

Special Focus
Data Acquisition 30

Under the Hood
A19 LED bulbs 38



Download
the **Digi-Key**
Toolbar today!

digikey.com/europe/toolbar

Digi-Key Smartphone Applications

YOUR PASSEY
TO THE INDUSTRY'S
LARGEST INVENTORY
OF IN-STOCK
ELECTRONIC
COMPONENTS



**FREE
SHIPPING**
ON ORDERS OVER €65!

Providing instant access
for design engineers and
purchasers to source the
electronic components they need
anytime, anywhere.

The industry's broadest product selection
available for immediate delivery

Find contact and ordering
information for your region at

www.digikey.com/europe

*A shipping charge of €18.00 (£12.00) will be billed on all orders of less than €65.00 (£50.00). All orders are shipped via UPS for delivery within 1-3 days (dependent on final destination). No handling fees. All prices are in euro and British pound sterling. If excessive weight or unique circumstances require deviation from this charge, customers will be contacted prior to shipping order. Digi-Key is an authorized distributor for all supplier partners. New product added daily. © 2011 Digi-Key Corporation, 701 Brooks Ave. South, Thief River Falls, MN 56701, USA

f t y+ GET CONNECTED

PUBLISHER

André Rousselot
+32 27400053
andre.rousselot@eetimes.be

EDITOR-IN-CHIEF

Julien Happich
+33 153907865
julien.happich@eetimes.be

EDITORS

Philip Ling
+44 1622746580
phil.ling@eetimes.be

Christoph Hammerschmidt

+49 8944450209
chammerschmidt@gmx.net

CONTRIBUTING EDITORS

Paul Buckley
+44 1962866460
paul@activewords.co.uk

Jean-Pierre Joosting

+44 7800548133
jean-pierre.joosting@eetimes.be

CIRCULATION & FINANCE

Luc Desimpel
luc.desimpel@eetimes.be

ADVERTISING PRODUCTION & REPRINTS

Lydia Gijsegom
lydia.gijsegom@eetimes.be

ART MANAGER

Jean-Paul Speliers

ACCOUNTING

Ricardo Pinto Ferreira

REGIONAL ADVERTISING REPRESENTATIVES

Contact information at:
<http://www.electronics-eetimes.com/en/about/sales-contacts.html>

EUROPEAN BUSINESS PRESS SA

144 Avenue Eugène Plasky
1030 Brussels - Belgium
Tel: +32 (0)2 740 00 50
Fax: +32 (0)2 740 00 59
www.electronics-eetimes.com
VAT Registration: BE 461.357.437
RPM: Brussels
Company Number: 0461357437



european
business press

© 2011 E.B.P. SA

CONTENTS AUGUST 2011

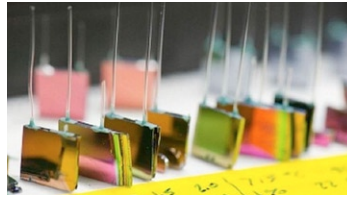

MIT's slabs of tungsten with billions of nanoscale pits engineered on their surface radiate absorbed heat at carefully chosen wavelengths, converting heat as photovoltaic-ready luminous energy. **5**

OPINION

- 4** **Uncommon Market:** Faked in China: learning from Apple's misery
- 50** **Last Word:** The universal IP platform and European IP startups to watch

COVER STORY

- 17** Gasoline, diesel or pumpable electrons?

NEWS & TECHNOLOGY

- 5** Photovoltaics energy-conversion system skips the sun
- 6** EUV delay to slow NAND supply
- Ferroelectrics fabbed on plastic
- 8** Ambient electromagnetic energy harvesting out of the printer
- 10** Silver-ink rollerball pen writes electric circuits
- 11** Semikron heads for e-mobility
- Intel Capital launches \$300M ultrabook fund
- 12** Multi-threaded analysis with multi-core models for emulation
- Embedding ultra-low cost 3D digital MEMS compasses in CMOS
- 13** Rare earths get rarer

- 14** Surround haptics
- 16** A million ARM cores to host brain simulator

DESIGN + PRODUCTS

SPECIAL FOCUS: ANALOG & MIXED SIGNAL

- 20** Pro audio techniques to improve sound quality in mobile devices
- 23** Haptics technology: picking up good vibrations

SPECIAL FOCUS:

DATA ACQUISITION

- 30** Record and replay in global navigation satellite system testing
- 32** Data logging without gaps
- 34** Achieving Gen2 Serial RapidIO throughput with low power FPGAs

UNDER THE HOOD:

- 38** A19 LED bulbs: What's under the frosting?

SPECIAL FOCUS:

PASSIVE COMPONENTS

- 40** Medium voltage capacitor discharge resistors in PFC

READER OFFER

- 46** Altera gives away two INK kits, worth 600 Euros each.

ELECTRONIC ENGINEERING TIMES EUROPE is published monthly in 2011 by European Business Press SA, 144 Avenue Plasky, 1030 Bruxelles, Belgium Tel: +32-2-740 00 50 Fax: +32-2-740 00 59 email: info@eetimes.be. VAT Registration: BE 461.357.437. RPM: Brussels. Volume 13, Issue 8 EE Times P 304128
It is free to qualified engineers and managers involved in engineering decisions - see: <http://www.electronics-eetimes.com/subscribe>
Copyright 2011 by European Business Press SA. All rights reserved. P 304128

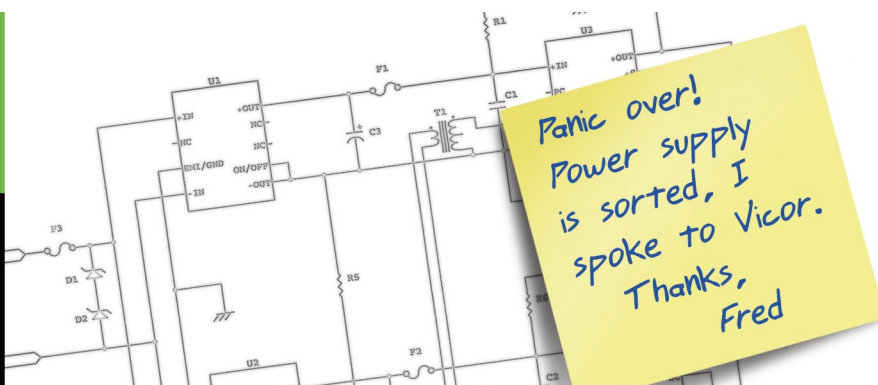

Power Problem Solved

- ✓ Proven Technology
- ✓ Fast Design Time
- ✓ Widest Product Range

Fred found it easy. So can you.
Go to vicoreurope.com/solved

Faked in China: learning from Apple's misery

By Andy Groom

FAKE STAFF, fake interior decoration and a complete shop full of fake electronic devices: The recent news regarding five bogus Apple stores in China; perfect one-to-one copies of the original shops, showed once again that there are no limits to the creativity and ingenuity of counterfeiters in all industries. However, I think the electronics industry was less surprised than others.

The electronics counterfeit industry is savvier than ever. Counterfeiters constantly find ever more novel ways to smuggle their illegal goods into the market. OEMs are aware of the danger of increasingly sophisticated counterfeits and the general numbers prove them right: The Rogers Review, estimated in the 2010 IP Crime Group Report that criminal gain from IP crime alone in the UK was £1.3 billion in 2006 with £900 million of that figure considered to be flowing into organised crime. And many parts of industry estimate that the figure is now even higher than this. Some industry experts go so far to suggest that counterfeit goods now represent around 10% of the entire electronics market.

As a result of this, electronics distributors have to guarantee the irrefutable authenticity of their products and one way to do this is to run an independent in-house third party testing facility. In my opinion third-party testers are the best choice to provide both an expert and objective evaluation of a component according to all necessary conformance, performance and industry requirements. However, in-depth inspection of every part in the supply chain is an impossible task. Ultra-modern counterfeit testing methods can also entail additional costs for OEMs. The Independent Distributors of Electronics Association (IDEA) has established an inspection standard, which is well recognised within the electronics industry and works very well as a fundamental checklist. This is the IDEA STD 1010. Benchmark testing standards are key to ensure the authenticity of electronic components, and the standard raises quality-conscious, upright indepen-

dent distributors to a higher level in the market, separating the wheat from the chaff. Indications of counterfeit in a component can be relatively minor. The IDEA 1010 standard details 50 inspection-checks for electronic components, characteristics of good components, and examples of quality and substandard parts.

Counterfeited electronic components might be sophisticated retapes of existing IP. Then



Groom: "In my opinion third-party testers are the best choice to provide both an expert and objective evaluation of a component."

again they might simply be a scrap from manufacturing that is salvaged and sold as new; components from discarded computers in the supply chain being shipped as recycled e-waste, or parts being plucked from the board and illegally re-labelled.

Using five different types of visual inspections most counterfeit components can be discovered with the IDEA STD 1010 examinations: part marking; surface (top and underside); edges; leads, and packaging and labels.

Surface-marking-examination looks at evidence of slight standings and scratch marks, while lead-checks simply involve ensuring there is nothing missing, and that no solder/flux are on the leads, as well as looking for evidence of heating or burn marks. Experi-

enced staff are also invaluable; even if a part number marking looks fine at first glance, if not located in the position where the inspector would expect to see it rings a warning bell and the part gets scrutinised further. The next stages for proof of authenticity are more detailed and investigative checks, which go beyond the industry's inspection standards and should be done by independent third-party test houses, by various means including de-capsulation to expose the chip inside, as well as the revision number, manufacturer's log, logos and part number. Currently most counterfeiters are unlikely to go into this level of detail, (that is, assuming they put a chip inside their packaging at all).

Looking for the manufacturer's signatures to ensure the genuineness of the part does not necessarily require deconstruction. X-ray inspections are still a very effective means to detect types of counterfeited parts; most effective when x-raying the ambiguous parts side-by-side with a 'known good part'. Comparing the lead, frame, footprint and location of the die within the package gives a very accurate indication of authenticity. There are further developments occurring in authenticity evaluation; laser surface authentication for example, involves analysing the naturally occurring random structure of a chip's surface and from this generating a signature or code unique to that surface. This code can then be used to authenticate and identify the item in the same way as a fingerprint. The serial code is naturally occurring and is not added by any manufacturing step, eliminating the danger of replication.

Looking at the example of the Apple stores, no matter how safe genuine testing methods are, counterfeiters never fail to impress.

While new techniques for testing emerge all the time, there really is no substitute for the fundamental testing methods. OEMs should put their trust in what they know to work best; unified industry standards and independent third party testing. The best thing a company can ever do to avoid counterfeits is simply to apply rigorous processes to make sure these fundamentals are in place. ■

Andy Groom is the Managing Director of distributor America II Europe www.americaiiurope.com

Photovoltaics energy-conversion system skips the sun

By Julien Happich

A NEW PHOTOVOLTAIC energy-conversion system developed at MIT can be powered solely by heat, generating electricity with no sunlight at all. While the principle involved is not new, a novel way of engineering the surface of a material to convert heat into precisely tuned wavelengths of light — selected to match the wavelengths that photovoltaic cells can best convert to electricity — makes the new system much more efficient than previous versions.

The key to this fine-tuned light emission lies in a material with billions of nanoscale pits etched on its surface. When the material absorbs heat, whether from the sun, a hydrocarbon fuel, a decaying radioisotope or any other source, the pitted surface radiates energy primarily at these carefully chosen wavelengths. Based on that technology, MIT researchers have made a button-sized power generator fuelled by butane that can run three times longer than a lithium-ion battery of the same weight. The device can then be recharged instantly, just by snapping in a tiny cartridge of fresh fuel. Another device, powered by a radioisotope that steadily produces heat from radioactive decay, could generate electricity for 30 years without refuelling or servicing. This would be well suited for spacecraft headed on long missions away from the sun.

“Being able to convert heat from various sources into electricity without mov-

ing parts would bring huge benefits,” says Ivan Celanovic, research engineer in MIT’s Institute for Soldier Nanotechnologies (ISN), “especially if we could do it efficiently, relatively inexpensively and on a small scale.” The solution, Celanovic says, is to design a thermal emitter that radiates only the wavelengths that the PV diode can absorb and convert into electricity, while suppressing other wavelengths. “But how do we find a material that has this magical property of emitting only at the wavelengths that we want?” asks Marin Soljčić, professor of physics and ISN researcher. The answer: make a photonic crystal by taking a sample of material and create some nanoscale features on its surface, for example a regularly repeating pattern of holes or ridges, so light propagates through the sample in a dramatically different way.

“By choosing how we design the nanostructure, we can create materials that have novel optical properties,” Soljčić says. “This gives us the ability to control and manipulate the behaviour of light.” The team, which also includes Peter Bermel, research scientist in the Research Laboratory for Electronics (RLE); Peter Fisher, professor of physics; and Michael Ghebrebrhan, a postdoc in RLE, used a slab of tungsten, engineering billions of tiny pits on its surface. When the slab heats up, it generates bright light with an altered emission spectrum because each

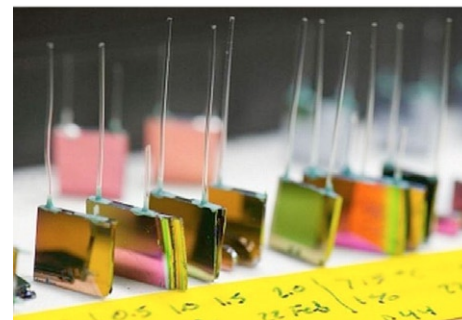

pit acts as a resonator, capable of giving off radiation at only certain wavelengths. This powerful approach - co-developed by John D. Joannopoulos, the Francis Wright Davis Professor of Physics and ISN director, and others - has been widely used to improve lasers, light-emitting diodes and even optical fibres. The MIT team, supported in part by a seed grant from the MIT Energy Initiative, is now working with collaborators at MIT and elsewhere to use it to create several novel electricity-generating devices. The button-like device that uses hydrocarbon fuels such as butane or propane as its heat source, known as a micro-TPV power generator, has at its heart a “micro-reactor” designed by Klavs Jensen, the Warren K. Lewis Professor of Chemical Engineering, and fabricated in the Microsystems Technology Laboratories. While the device achieves a fuel-to-electricity conversion efficiency three times greater than that of a lithium-ion battery of the same size and weight, Celanovic is confident that with further work his team can triple the current energy density. ■

ST Micro opens lab for humanoid robot

By Nicolas Mokhoff

STMICROELECTRONICS AND SCUOLA Superiore Sant’Anna of Pisa announced the creation of a joint laboratory for research and innovation in bio-robotics, smart systems and microelectronics. The work at the new laboratory in Catania, Italy is to lead to a better understanding of the physical design of bodies and the

organization of their sensory and nervous systems. Past collaboration between ST and Scuola Superiore Sant’Anna resulted in joint projects including DustBot, a scientific platform integrating self-driven, self-navigating ‘service robots’ for selective waste collection and street cleaning in city centers. Going forward, experts will be collaborating

to develop smart toys equipped with motion and pressure sensors for early diagnosis of neuro-developmental delays and autistic pathologies in small children. While the child plays with the smart toy, the system will constantly monitor the child’s movement and posture, as well as how he/she grasps or holds the toy. ■

EUV delay will slow NAND supply growth

By Rick Merritt

DELAYS DELIVERING next-generation lithography will slow the growth in supply of NAND flash, said the chief technologist of SanDisk in a keynote address at the Flash Memory Summit in Santa Clara, California.

In an otherwise upbeat assessment of the outlook for the flash market, Yoram Cedar waved a yellow flag about delays fielding extreme ultraviolet lithography. The lack of EUV tools will result in the historical increases in flash supply and decreases in cost to be more moderate with future process technologies, he said.

Existing immersion lithography tools will serve flash makers down to geometries of less than 10nm, two generations from today's processes, he said. In addition, vendors are working to create 3-D stacks of NAND strings using existing fab tools to further boost capacity and supply, he added. Further in the future, chip makers including SanDisk are developing 3-D structures that use changes in resistance to create denser

chips. But the so-called resistive RAM will require EUV tools, he said.

Cedar declined to give any specifics about the timeframe for EUV or the status of the current 3-D chip research. However, he did say chip makers expect to ship 64 and 128 Gbit flash devices using immersion tools.

"Many people in the semiconductor industry are very concerned about EUV not only from the standpoint of its availability but also its cost, these things will cost many millions of dollars," said one audience member in question to Cedar after the keynote. Some pre-production EUV tools reportedly began shipping in January. Costs for the tools could soar as high as \$120 million, according to some reports. Cedar expressed optimism that EUV systems will be affordable.

He also noted historical fears of an end to Moore's Law have so far been unfounded.

"When we were at 90nm, we thought 56nm was difficult and may be the end of

the game," he said. The good news is flash demand is broad and strong. Flash is expected to grow 25 percent on a compound basis through 2015, nearly double the rate of hard disk storage and far above DRAM at only one percent, he said. About a third of all NAND bits will go to smartphones by 2015 when as many as 1.1 billion units ship, Cedar said. Tablets will take another 15 percent of NAND bits for 327 million systems that year, he added.

"Tablets represent a sizeable market that came from nowhere," he said. "There is so much new development here that wasn't forecast three or four years ago, and there's no reason this will not continue," he added. He projected solid-state drives will consume 25 percent of NAND bits, selling into 133 million units for clients and 12 million for servers. The rest of NAND supply, about 26 percent, will go into existing systems such as MP3 players, USB drives and digital cameras, he said. ■

Ferroelectrics fabbed on plastic

By R. Colin Johnson

FERROELECTRIC MEMORIES, energy harvesting arrays, sensors and actuators could soon be fabricated on plastic substrates, according to researchers at the Georgia Institute of Technology, who recently demonstrated a new low-temperature process using an atomic-force microscope (AFM).

Using a process called thermochemical nano-lithography, a team led by Georgia Tech professor Nazanin Bassiri-Gharb has discovered a low-temperature process for depositing ferroelectric materials on plastic substrates.

The group, which also includes postdoctoral fellow Suenne Kim, professor Elisa Riedo, and graduate assistant Yaser Bastani, recently demonstrated nanoscale ferroelectric structures that could be used to fabricate ferroelectric devices on cheap polymers.

Using the heated tip of an AFM, the group

fabricated ferroelectric structures suitable for semiconductor devices or MEMS-like sensors and actuators, including wires just 30 nanometers wide and spheres just 10 nanometers in diameter.

For ferroelectric memories, the group estimates that densities as high as 200 gigabytes per square inch could be fabricated with their process.

The research was performed in cooperation with the University of Illinois and the University of Nebraska. Funding was provided by the National Science Foundation and the U.S. Department of Energy. ■

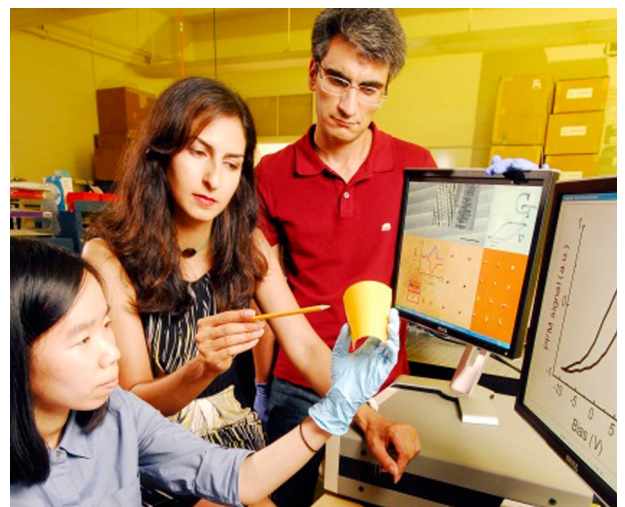

Georgia Tech postdoctoral fellow Suenne Kim (left) holds a sample of flexible polyimide substrate holding ferroelectric nanostructures, produced in the lab of professor Nazanin Bassiri-Gharb (center) while graduate assistant Yaser Bastani observes. Photo credit: Gary Meek, Georgia Tech.



mouser.com

Distributing semiconductors and electronic components for design engineers.

Authorised Distributor

We speak customer service fluently.



When it comes to delivering the newest products, faster, local knowledge is everything. Mouser has worldwide coverage providing professional and excellent sales service and technical support with invaluable local knowledge and experience.

Germany

Ganghoferstrasse 34
82216 Maisach-Gernlinden
Germany
+49 (0) 8142 65279 10
munich@mouser.com

Italy

Centro Direzionale
Milanofiori
Strada 1 Palazzo E1
20090 Assago-MI
Italy
+39 025 750 65 71
italy@mouser.com

United Kingdom

Suite C, First Floor
Artisan Building
Hillbottom Road
High Wycombe
Bucks. HP12 4HJ, UK
+44 (0) 1494-467490
uk@mouser.com

Spain

Passeig del Ferrocarril
335 2-3
Castelldefels
08860 Barcelona
Spain
+34 936455263
spain@mouser.com

France

Le Voltaire
1, Avenue Leo Lagrange
19100 Brive-La-Gaillarde
France
+33 5 55 85 79 96
france@mouser.com

Czech Republic

Palackeho trida
3019 / 153b
61200 Brno
Czech Republic
+420 517070880
czech@mouser.com

Israel

1 Hanofar Street
43662 Raanana
Israel
+972 9 7783020
israelsales@mouser.com



mouser.com

The Newest Products for Your Newest Designs®



a tti company

Ambient electromagnetic energy harvesting out of the printer

By Julien Happich

RESEARCHERS FROM THE GEORGIA

Institute of Technology have discovered a way to capture and harness energy transmitted by such sources as radio and television transmitters, cell phone networks and satellite communications systems. By scavenging this ambient energy from the air around us, the technique could provide a new way to power networks of wireless sensors, microprocessors and communications chips.

“There is a large amount of electromagnetic energy all around us, but nobody has been able to tap into it,” said Manos Tentzeris, a professor in the Georgia Tech School of Electrical and Computer Engineering who is leading the research. “We are using an ultra-wideband antenna that lets us exploit a variety of signals in different frequency ranges, giving us greatly increased power-gathering capability.”

Tentzeris and his team are using inkjet printers with a special ink containing silver nanoparticles and/or other nanoparticles in an emulsion. They can combine sensors, antennas and energy scavenging capabilities on paper or flexible polymers. The resulting self-powered wireless sensors could be used for chemical, biological, heat and stress sensing for defense and industry; RFID tagging for manufacturing and shipping, and monitoring tasks in many fields including

communications and power usage.

Communications devices transmit energy in many different frequency ranges, or bands. The team’s scavenging devices can capture this energy, convert it from AC to DC, and then store it in capacitors and batteries. The scavenging technology can take advantage presently of frequencies from FM radio to radar, a range spanning 100MHz to 15GHz or higher. Scavenging experiments using TV bands have already yielded power amounting to hundreds of microwatts, and multi-band systems are expected to generate one milliwatt or more. That amount of power is enough to operate many small electronic devices, including a variety of sensors and microprocessors.

By combining energy scavenging technology with supercapacitors and cycled operation, the Georgia Tech team expects to power devices requiring above 50 milliwatts. In this approach, energy builds up in a battery-like supercapacitor and is used when the required power level is reached. The researchers have already successfully operated a temperature sensor using electromagnetic energy captured from a television station that was half a kilometer distant. They are preparing another demonstration in which a microprocessor-based microcontroller would be activated simply by holding it in

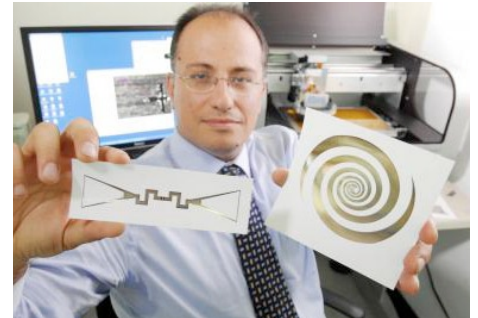

Georgia Tech School of Electrical and Computer Engineering professor Manos Tentzeris holds a sensor (left) and an ultra-broadband spiral antenna for wearable energy-scavenging applications. Georgia Tech Photo: Gary Meek.

the air.

Exploiting a range of electromagnetic bands increases the dependability of energy scavenging devices, explained Tentzeris, who is also a faculty researcher in the Georgia Electronic Design Center at Georgia Tech. If one frequency range fades temporarily due to usage variations, the system can still exploit other frequencies. The scavenging device could be used by itself or in tandem with other generating technologies. For example, scavenged energy could assist a solar element to charge a battery during the day. At night, when solar cells don’t provide power, scavenged energy would continue to increase the battery charge or would prevent discharging. ■

Multi-threading API aims to ease portability

By Philip Ling

THE MULTICORE ASSOCIATION has announced a new Working Group, which aims to produce an API for multicore task management (MTAPI). If successful, the API could be implemented by IDMs and tool vendors to ease the portability of multithreaded software on the latest multicore processors.

According to Urs Gleim, program manager for Parallel Processing Systems at Siemens AG and chair of the MTAPI Working Group, the majority of APIs currently targeting multicore devices are proprietary and as such do

not promote portability of application code between platforms.

One of the goals of the MTAPI Working Group is to produce a specification that will enable greater code reuse between hardware platforms. At the moment, some tools support pThreads, but little else. It is hoped that MTAPI will be adopted by tools vendors, as well as being implemented in operating systems and kernels, to enable greater portability of code. One of the Group’s ambitions is to better support heterogeneous SoCs; where

multiple but different cores are implemented, such as graphics accelerators and DSPs sitting alongside general purpose processors. Here, managing the parallelisation of tasks becomes increasingly difficult and it is hoped that a standardised API resident on each core will make it simpler to fully utilise the resources of each core.

The Working Group is aiming to finalise the scope of MTAPI by November 2011, with the first draft of the specification being circulated in February 2012. ■

SENSING 2011 TECHNOLOGY

TEST • MEASUREMENT • INSTRUMENTATION

27TH - 28TH SEPTEMBER 2011 - NEC BIRMINGHAM

Visit us on stand D4



THE LATEST AND GREATEST SENSING TECHNOLOGY

- > Sensor ICs and latest technologies for a range of applications
- > MEMS and pressure sensors from leading brands in the industry
- > Resistive, inductive, optical and capacitive touch and proximity sensors
- > Hall effect sensors from world leading suppliers



www.farnell.com/sensing

element14

www.element14.com



Design with the best

Silver-ink rollerball pen writes electric circuits and interconnects

By Julien Happich

UNIVERSITY OF ILLINOIS ENGINEERS

have developed a silver-inked rollerball pen capable of writing electrical circuits and interconnects on paper, wood and other surfaces.

The pen is writing whole new chapters in low-cost, flexible and disposable electronics. Led by Jennifer Lewis, the Hans Thurnauer professor of materials science and engineering at the U. of I., and Jennifer Bernhard, a professor of electrical and computer engineering, the team published its work in the journal *Advanced Materials*.

“Pen-based printing allows one to construct electronic devices ‘on-the-fly,’” said Lewis, the director of the Frederick Seitz Materials Research Laboratory at the U. of I. “This is an important step toward enabling desktop manufacturing (or personal fabrication) using very low cost, ubiquitous printing tools.” While it looks like a typical silver-coloured rollerball pen, this pen’s ink is a solution of real silver. After writing, the liquid in the ink dries to leave conductive silver pathways, akin to paper-mounted wires. The ink main-

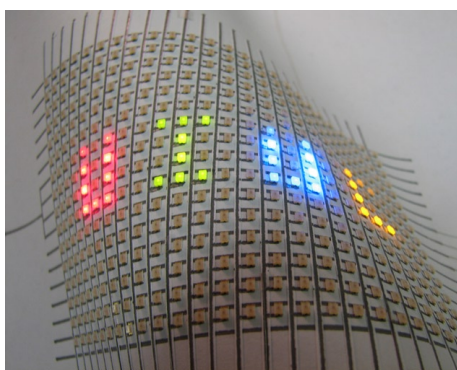

A matrix of LEDs connected through hand-written lines of conductive ink. Photo by Bok Yeop Ahn.

tains its conductivity through multiple bends and folds of the paper, enabling devices with great flexibility and conformability.

Metallic inks have been used in approaches using inkjet printers to fabricate electronic devices, but the pen offers freedom and flexibility to apply ink directly to paper or other rough surfaces instantly, at low cost and without programming. “The key advantage of the pen is that the costly printers and print-heads typically required for inkjet or other printing approaches are replaced with an inexpensive, hand-held writing tool,” said Lewis, who is

also affiliated with the Beckman Institute for Advanced Science and Technology.

The ability to create freestyle conductive pathways enables new possibilities in art, disposable electronics and folded three-dimensional devices. For example, the researchers used the silver pen to sketch a copy of the painting “Sae-Han-Do” by Jung Hee Kim, which portrays a house, trees and Chinese text.

The ink serves as wiring for an LED mounted on the roof of the house, powered by a five-volt battery connected to the edge of the painting. The researchers also have demonstrated a flexible LED display on paper, conductive text and three-dimensional radio-frequency antennas.

Next, the researchers plan to expand the palette of inks to enable pen-on-paper writing of other electronic and ionically conductive materials. The U.S. Department of Energy supported this work. Co-authors were graduate student Analisa Russo and postdoctoral researchers Bok Yeop Ahn, Jacob Adams and Eric Duoss. ■

Smart skin powered by solar cells

By Julien Happich

IN ANOTHER DEPARTMENT OF the University of Illinois, researchers have developed a device platform that combines electronic components for sensing, medical diagnostics, communications and human-machine interfaces, all on an ultrathin skin-like patch that mounts directly onto the skin with the ease, flexibility and comfort of a temporary tattoo and is powered by solar cells.

The circuit bends, wrinkles and stretches with the mechanical properties of skin. The researchers demonstrated their concept through a diverse array of electronic components mounted on a thin, rubbery substrate, including sensors, LEDs, transistors, radio frequency capacitors, wireless antennas, and conductive coils and solar cells for power.

“We threw everything in our bag of tricks

onto that platform, and then added a few other new ideas on top of those, to show that we could make it work,” said John A. Rogers, the Lee J. Flory-Founder Chair in engineering. The patches are initially mounted on a thin sheet of water-soluble plastic, then laminated to the skin with water - just like applying a temporary tattoo. Alternately, the electronic components can be applied directly to a temporary tattoo itself, providing concealment for the electronics.

The team developed a device geometry they call filamentary serpentine, in which the circuits for the various devices are fabricated as tiny, squiggled wires. When mounted on thin, soft rubber sheets, the wavy, snakelike shape allows them to bend, twist, scrunch and stretch while maintain-

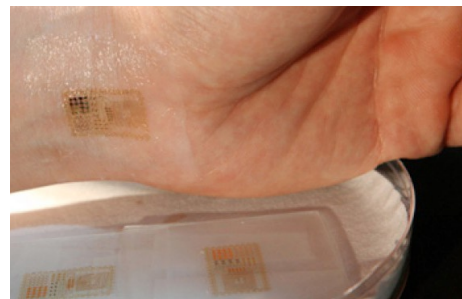

The ultrathin skin-like electronic patch from the University of Illinois is powered by solar cells. ing functionality.

The researchers used simple adaptations of techniques used in the semiconductor industry, so the patches are easily scalable and manufacturable. The device company *micro*, which Rogers co-founded, is already working to commercialize certain versions of the technology. ■

Semikron heads for e-mobility

By Christoph Hammerschmidt

POWER SEMICONDUCTOR manufacturer Semikron GmbH throws the switches towards the growing business with hybrid and battery electric drives for cars. The company already has a track record with forklifts, boat drives and similar concepts - now it finds it is time to get on board of mainstream cars.

The company based in Nuremberg runs a production line for power semiconductors. Insiders believe that it is one of the largest manufacturing facilities for bipolar power devices in Europe, perhaps in the world. The IGBTs, power transistors, thyristors and diodes are used for Semikron's product line of intelligent power modules, inverters and CIBs (Converter-Inverter-Brakes) for industrial, energy and vehicle applications.

Over the past years, the company has built up significant expertise for electric and hybrid drive vehicles, said Harald Jaeger, General Manager of Semikron's Automotive Systems division, in an interview with EE Times Europe. The power electronics systems manufactured under the brand name SKAI hitherto were designed for off-road vehicles such as forklifts, trucks, construction vehicles and large agricultural vehicles,

Jaeger explained. "For forklifts alone, we have produced more than half a million systems," he said.

The company believes that now the time is right to address larger markets and benefit from the growth chances in the electric and hybrid electric passenger car markets. "Currently, this market is characterized by a lack of established structures - there is no established base of suppliers for electric powertrains yet, and new players are emerging", he said. "While many customers don't have long-term expertise in power electronics, we do."

Half a year ago, the company has launched a joint venture with Swiss-based engine control technology drivetek AG. This joint venture, SKAItek, is dedicated to developing motor control software for HEVs and electric vehicles. In addition, Semikron has acquired another technology expert company for hybrid and electric powertrains, VePoint. Now Semikron intends to leave its niche as vendor of power inverters and offer



complete systems. Chief developer Reinhard Helldörfer sees the competencies of his company not only in power semiconductors but also in caps, coolers, inverters and system integration - and now, through its SKAItek activities,

in designing intelligent motor controllers and the associated software.

The company has already designed a power electronics platform for low to medium volume applications. This platform is flexible enough to be integrated into various and different vehicles and could help vehicle vendors to quickly roll out electric or hybrid electric cars. For high volume applications, the company plans to offer highly optimized and tailored products. A number of different designs covering the power range of up to 150 kW and handling voltages of up to 1200V are already available. The product portfolio of Semikron's automotive division also includes the QUASAR motor control software and a 30kW axial flow electric motor for electric vehicles. "We have plenty of headroom to grow", Jaeger said. ■

Intel Capital launches \$300M ultrabook fund

By Rick Merritt

INTEL CAPITAL LAUNCHED a \$300 million Ultrabook Fund to bankroll startups working on technologies in line with its new concept for next-generation notebooks. The CPU giant is under pressure from a coming generation of ARM-based mobile systems in the works that will use Microsoft Windows 8.

The \$300 million represents additional money Intel Capital will spend over the next three to four years in a wide variety of areas related to ultrabooks. Areas of interest include technologies to "enhance the user experience, such as sensors, extend battery life and help enable smaller and thinner form factors," said a company spokesman.

Intel announced the ultrabook concept at Computex in Taipei in June. The goal is a thin and light notebook that also has tablet features such as a touch screen.

"From what Intel said this will have the sveltiness of a Macbook Air and be able to work as a tablet PC—I think that's a winning combination," said Nathan Brookwood, principal of market watcher Insight64 (Saratoga, Calif.), a long time user of the Windows business tablets that preceded the Apple iPad but have not had as much market success.

"What's constrained the Microsoft Tablet PC software is it was designed to work with all existing Windows apps," said Brookwood. "If they create something more like an Android interface with buttons you can touch without needing a stylus that will be good," he said. "I get very frustrated with some of the limitations of the [Android] Honeycomb tablets that I know would not be a problem with an x86 processor and Windows 7 or 8," he added.

The Taipei announcement about the ultrabook was no accident. Taiwan's notebook makers are working in tandem both on Intel ultrabooks and on ARM-based mobile systems. Microsoft is expected to release versions of Windows 8 for Qualcomm's Snapdragon, Nvidia's Tegra and Texas Instrument's OMAP processors.

It marks the first time a major Windows release will run on non-x86 processors. Nvidia plans a whole new line of ARM-based CPUs roughly timed with the Windows 8 launch.

With the Ultrabook Fund "a company thinking about building some extensions of Windows 8 on ARM might instead focus on Windows 8 on x86 and minimize what they are doing on ARM," said Brookwood. ■

Multi-threaded analysis now uses multi-core models for real-world emulation

By Philip Ling

VECTOR FABRICS HAS OFFICIALLY released vfThreaded, a semi-automated approach to 'tuning' sequential code for parallel execution on multicore processors. It effectively replaces the company's existing tool, vfAnalyst, but focuses initially on Intel processors and Windows-based applications. As such, it is described as a lower cost alternative to vfEmbedded, which targets both Intel and ARM processors. Unlike vfAnalyst, the new tool uses models of the actual target processor, to give a better representation of the performance boost the user can expect from

parallelising their code. Today vfThreaded supports the multicore variants of Intel's i5 and Atom processors and the official release of vfThreaded comes a few weeks after Vector Fabrics became an Intel partner.

According to Marco Jacobs, marketing director for Vector Fabrics, vfThreaded targets a different market to vfEmbedded by focusing on the Windows-based applications running on an Intel platform, explaining that parallel programming can return as much as 16x the performance and 2x lower power.

The tool works by first analysing the code

to find 'hot spots' and dependencies, then allows the user to partition using the visual interface, before implementing the changes made at the code level and then running the code on the emulated processor models.

Once a satisfactory performance point has been found, the tool then delivers a 'recipe' showing what changes the software engineers should implement. As with the company's other offerings, vfThreaded runs under a 'Software as a Service' model in an Amazon-hosted cloud-based server, on a monthly subscription. ■

Baolab embeds ultra-low cost 3D digital MEMS compasses in CMOS

MEMS

By Julien Happich

UNTIL NOW, 3D COMPASSES have typically used non-standard technologies such as magneto-resistive materials or Hall-effect structures combined with magnetic field concentrators to detect the direction of the Earth's magnetic field.

Baolab Microsystems is first to design a pure CMOS Lorentz force MEMS sensor and, as a result, its new 3D Digital NanoCompass matches performance benchmarks for sensitivity, power consumption and package size, but at a dramatically lower cost. An additional unique feature resulting from this integration is that the device auto-calibrates to maintain consistent accuracy.

The BLBC3-D NanoCompass is the first product that will be made using Baolab's breakthrough NanoEMS technology. NanoEMS enables nanoscale MEMSs to be built using standard high-volume CMOS lines and fully integrated monolithically with the analogue and digital electronics. The MEMS elements are defined during the normal CMOS production process within the existing metal interconnect layers of the wafer.

The MEMS structure, a moveable aluminium plate suspended by springs, is constructed using the metal interconnect layers of the

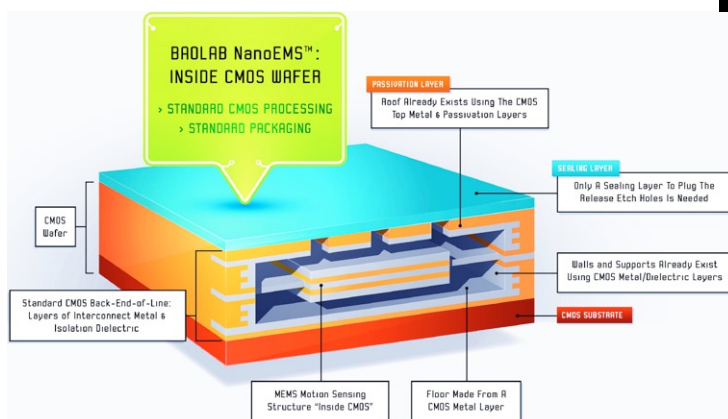

CMOS chip by etching away the Inter Metal Dielectric (IMD) using vapour HF. When a current passes through the plate, it experiences a force (the Lorentz force) proportional to the surrounding Earth's magnetic field. The resulting displacement is measured using capacitive detection between the moveable plate and fixed electrodes around it, sensing the magnetic field in the x, y and z directions with a single NanoEMS chip.

Hall effect sensors work well for magnetic field perpendicular to the chip (z direction) but less so in the x and y planes, and are not pure CMOS solutions as they require post processing to deposit some magnetic material on top of the wafer to increase their sensitivity (Integrated Magnetic Concentrator). This adds to the cost

of manufacture, as does the additional processing required to realise compass devices from magneto-resistive technologies such as AMR and GMR (Anisotropic Magnetoresistance and Giant Magnetoresistance). Other

benefits of Lorentz over Hall include lower power consumption due to the use of metallic conductors to carry the current, increased sensitivity using mechanical resonance and no magnetic saturation issues. Until now, the Lorentz force approach has not been used extensively due to the cost of manufacture using conventional MEMS techniques, but it is perfectly suited to the mechanical structures supported by Baolab's NanoEMS. Built in a standard CMOS process flow, NanoEMS makes it possible to manufacture the devices at a fraction of the cost. Engineering samples of the BLBC3-D NanoCompass will be available in 2012 along with a comprehensive evaluation kit. It provides 5 degree heading resolution and 13-bits per axis. ■

Rare earths get rarer

By R. Colin Johnson

RARE EARTH MATERIALS are becoming increasingly rare as dominant supplier China tightens restrictions on production, essentially cutting already short-supply exports by a third. As a result, rare earth prices are skyrocketing in a market where supply can only meet only about 40 percent of the demand outside China, according to a recent report from rare earths expert Dudley Kingsnorth, executive director of the Industrial Minerals Co. of Australia. "Prices for rare earths are going wild," said Mike Pugh, director of operations for Intematix Corp. "For instance, the price of europium more than doubled during a three-week period in June of this year."



The U.S., Canada and Australia all have strategic efforts underway to reopen rare earth mines outside China, including new mines in Russia and Malaysia. Still, these new mines are not expected to significantly reduce the shortfall for at least three years. As a result, hoarding and price gouging are already rampant as is a concerted effort by manufacturers to either move manufacturing operations to China or find alternatives to rare earths. Rare earths are used in slurries for mechanical planarization of everything from glass to semiconductor wafers. Chip makers are resorting to silicates and other minerals to substitute for rare earths, but the biggest squeeze is being felt by makers of phosphors for everything from fluorescent bulbs to white LEDs.

Phosphor maker Intematix (Fremont, Calif.) is taking a two-prong approach to rare earth shortages—moving some of its manufacturing to China while developing alternate phosphors in the U.S. "By manufacturing our aluminate and garnet phosphors in China, we can buy our rare earth materials there instead of having to export them," said Pugh. "In the U.S., we are making our nitride and silicate phosphors which use only very small quantities of rare earths." Intematix manufactures its aluminates (green) and garnets (yellow) in China to side-step export restrictions, but makes its rare-earth-light nitrides (red) and silicates (yellow, orange) in its U.S. production facility.

These nitride- and silicate-based phosphors can substitute for the heavily rare-earth-doped aluminate and garnet phosphors that are traditionally used for fluorescent bulbs and white LEDs, thus side-stepping the rare earth scarcity problem, but at a price. Nitride-based phosphors, for instance, are more than three times as expensive as traditional aluminate- and garnet-phosphors, both of which are heavily doped with rare earth materials.

"When you get a quote on the price of nitride phosphors it knocks your socks off," said Pugh. "But when you realize how little you need of them they become very affordable." One bright spot in the rare earth market is that shortages may accelerate the move to solid-state lighting since much less phosphor is needed to coat the inside of an LED compared to a fluorescent bulb. A blue LED can be used to pump green silicate phosphors mixed with red and yellow nitride phosphors to make white light. That combination uses few rare earths. Nitride phosphors, in particular, are very rugged, allowing them to be placed very close to the semiconductor junction of a blue LED, further reducing the amount of material needed to make white light. ■

MAXIMUM SELECTION IN PCB PINS & RECEPTACLES

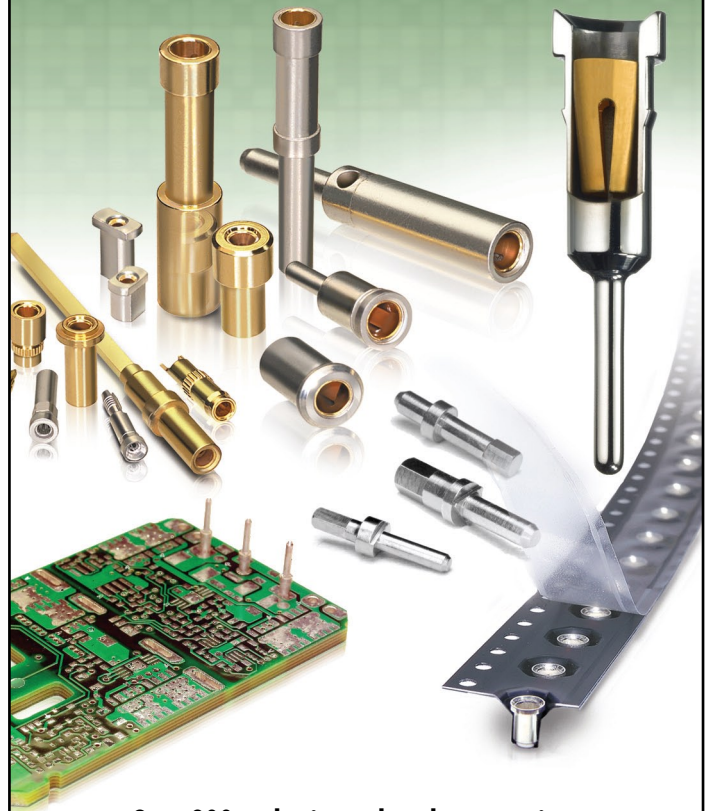

Over 800 styles in stock and more options than any manufacturer in North America

Available in diameters
from .008" (.20mm) to .250" (6.35mm)

Receptacles feature a 4 or 6 finger beryllium copper contact to ensure integrity of connection

Suitable for applications subject to high amounts of vibration and shock or for use in harsh environments

Don't see what you need?
Rapid prototyping and custom designs are our specialty.

MILL-MAX

Maximum products.
Maximum inventory.
Maximum value.

www.mill-max.com/EETE621



Follow us
MillMaxMfg



Mill-Max Mfg. Corp.

Surround haptics extend tactile perception beyond simple actuators

By Julien Happich

A NEW TACTILE TECHNOLOGY developed at Disney Research, Pittsburgh (DRP), called Surround Haptics, makes it possible for video game players and film viewers to feel a wide variety of sensations, from the smoothness of a finger being drawn against skin to the jolt of a collision. The technology is based on rigorous psychophysical experiments and new models of tactile perception.

In a demonstration developed in collaboration with Carnegie Mellon University and others, the technology enhances a high-intensity driving simulator game in collaboration with Disney's Black Rock Studio. With players seated in a chair outfitted with inexpensive vibrating actuators, Surround Haptics enables them to feel road imperfections and objects falling on the car, sense skidding, braking and acceleration, and experience ripples of sensation when cars collide or jump and land.

"Although we have only implemented Surround Haptics with a gaming chair to date, the technology can be easily embedded into clothing, gloves, sports equipment and mobile computing devices," said Ivan Pou-



pyrev, senior research scientist at DRP, who invented and developed Surround Haptics with Ali Israr, also of DRP. "This technology has the capability of enhancing the perception of flying or falling, of shrinking or growing, of feeling bugs creeping on your skin. The possibilities are endless."

The DRP researchers have accomplished this feat by designing an algorithm for controlling an array of vibrating actuators in such a way as to create "virtual actuators" anywhere within the grid of actuators. A virtual actuator, Poupyrev said, can be created between any two physical actuators; the user has the illusion of feeling only the virtual actuator. As a result, users don't feel the gen-

eral buzzing or pulsing typical of most haptic devices today, but can feel discrete, continuous motions such as a finger tracing a pattern on skin.

The phenomenon of phantom sensations created by actuators has been known for more

than 50 years, but its use in tactile displays has been limited because of an incomplete understanding of control mechanisms. DRP researchers were able to develop their control algorithm by systematically measuring users' ability to feel physical actuators vs. virtual actuators under a variety of stimulation levels. They then developed control models that were validated by further psychophysical experiments. In addition to enhancing user experiences with interactive games, movies and music, Surround Haptics' underlying technology promises to provide new tactile means of communication for the blind, emergency workers, vehicle operators, athletes and others. ■

TSMC's A6 processor to respin, says report

By Peter Clarke

FOUNDRY CHIPMAKER Taiwan Semiconductor Manufacturing Co (TSMC) – said to have started trial manufacturing of the ARM-based A6 processor for Apple – will put the IC through another tape-out for the "production design" in the first quarter of 2012, according to the Taiwan Economic News.

As a result of the respin of the design, production volumes of the A6 will not be available from TSMC until the second quarter of 2012 at the soonest, the report said referencing unnamed industry sources.

The A6, rumored to be a quad-core design, was expected to debut inside a yet more powerful iPad 3 tablet computer from Apple, which some thought could arrive this year.

One potential reason of the respin is that TSMC plans to use 3-D stacking technologies along with its 28-nm manufacturing process in the production of the A6 for Apple. The use of a specialized silicon interposer and bump-on-trace interconnect may produce specific requirements in the main processor die.

Samsung has been the sole supplier of the previous iterations of the Apple processor, the A4 and the A5. However, the use of company-proprietary packaging technology would count against the possibility that Apple is seeking to qualify both Samsung and TSMC and operate them as mutual second-sources. A major reason why TSMC has not

handled Apple's processor manufacturing to date is because the company has effectively been sold out with existing customers such as Nvidia and Qualcomm, the report said.

TSMC now expects manufacturing capacity utilization to dip to 92 percent in the third quarter, from 99 percent, and has forecast that its combined revenue will drop by between 6 and 8 percent sequentially in the third quarter, normally a quarter when sales are growing.

Packaging house Advanced Semiconductor Engineering Inc. partnered with TSMC to develop the 3-D chip packaging technology and so should benefit from the A6 processor business in 2012, the report said. ■

A real broadside!



Top performance on small surface areas with low-ohmic precision resistors

By reversal of the length to width ratio, our VLx series resistors have larger soldering and contact pads, giving them:

- better heat dissipation, $R_{thi} < 20K/W$
- higher power rating: 2 W for size 1020, 1 W for size 0612
- significant increase in mechanical stability



ISABELLENHÜTTE

Telephone: +49 (27 71) 9 34-0
sales.components@isabellenhuetten.de
www.isabellenhuetten.de

Innovation from tradition

A million ARM cores to host brain simulator

By Peter Clarke

UP TO A MILLION ARM PROCESSOR cores are going to be linked together to simulate the workings of the human brain in a research project in the U.K. Chips, designed at Manchester University and manufactured in Taiwan, form the building blocks for a massively parallel computer called SpiNNaker (Spiking Neural Network architecture).

The specialized chips, based on an old ARM instruction set architecture, were delivered to the university last month where they have subsequently passed functionality tests.

SpiNNaker is a joint project between the universities of Manchester, Southampton, Cambridge and Sheffield and has been funded with a £5 million (about \$8 million) government grant. Professor Steve Furber of the University of Manchester has been studying brain function and architecture for several years, but is also well known as one of the co-designers of the Acorn RISC Machine, a microprocessor that is the forerunner of today's ARM processor cores.

"We have small simulations running now, and will be scaling up over the next 18 months," said Professor Furber.

There are about 100 billion neurons with 1,000 trillion connections in the human brain. Even a machine with one million

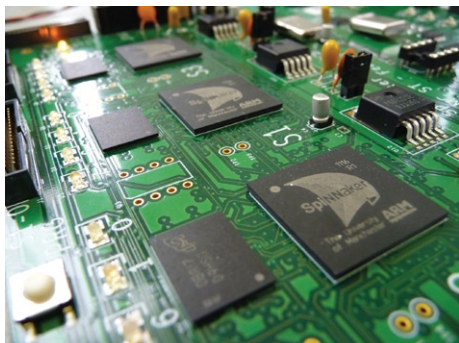

SpiNNaker's ARM chips shown under test. The first test chip was designed in 2009; the latest implementation includes 18 ARM processors per silicon die.

of the specialized ARM processor cores developed at Manchester would only allow modeling of about 1 percent of the human brain, the researchers said.

Neurons in the brain transmit information as analog electrical spikes. In the SpiNNaker machine these will be modeled as packets of descriptive data.

The neuronal processing of these spikes is then run as models or virtual neurons running on the ARM processors. The architecture and use of packetized digital data means that SpiNNaker can transmit spikes as quickly as the brain with many fewer physical connections.

An original test chip was designed by Professor Furber's team in 2009 but the latest implementation includes 18 ARM processors per silicon die which come packaged with a memory die and have a power budget of about one watt. The chip has been manufactured by UMC (Hsinchu, Taiwan) in 130-nm CMOS. It has a complexity of about 100 million transistors although this is mainly in 55 32-kbyte SRAM blocks distributed across the die, Professor Furber said.

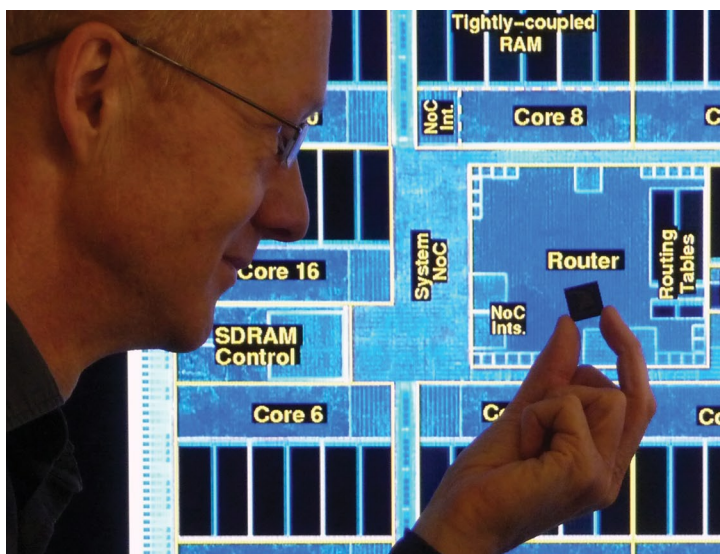

Research fellow Steve Temple (l.), who had a role in the SpiNNaker chip development, and Manchester professor Steve Furber in front of a layout of the SpiNNaker chip.

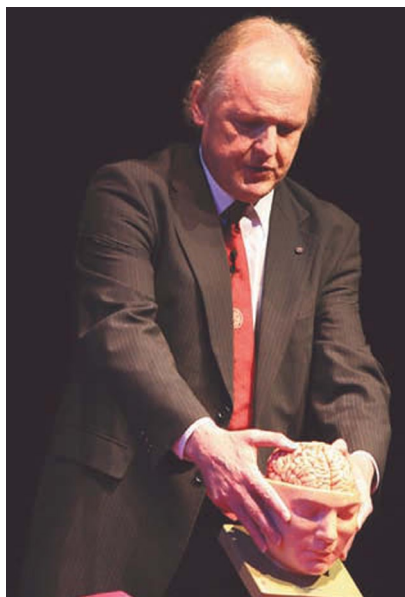

Furber discusses the human brain at a recent lecture.

The accompanying memory die is a 1-Gbit DDR SDRAM from Micron Technology Inc. (Boise, Idaho) that operates at up to 166-MHz. These were sourced as known good die and then had packaged with the SpiNNaker ARM die in a 300-BGA package, Professor Furber said.

"We don't know how the brain works as an information-processing system, and we do need to find out. We hope that our machine will enable significant progress towards achieving this understanding," said Professor Furber, in a statement.

ARM has been supporting the SpiNNaker project since it was approached in 2005 by providing its processor and physical IP to the team. ■

Gasoline, diesel or pumpable electrons?

By R. Colin Johnson

ELECTRONICS HAS ALREADY transformed society. By harnessing electricity to perform the operations that were once performed manually, computers have made obsolete legions of mechanical devices, from adding machines to carburetors. Now electronics is poised to replace the gas-guzzling internal combustion engine with electric motors driven by pumpable fuels that bear electrons as their active elements.

Indeed, if an ambitious startup with MIT roots and DOE funding has its way, within five years you may see a new pump, labeled Cambridge Crude, appear next to those for the lead-free and diesel at your local service station.

Ever since Italian physicist Alessandro Volta invented the electrochemical cell in 1792, voltage per cell has been restricted by the chemical reaction. The typical limit for the vast majority of battery chemistries is 1.5 volts; modern lithium-ion batteries achieve 3.6 V per cell, albeit at a trade-off of a much higher cost per kilowatt-hour.

The term battery predates even Volta's work. It was coined by Benjamin Franklin, who in 1748 used Leyden jars to capture electrons discharged during lightning storms, yielding what were effectively the first manmade capacitors. Franklin came up with the idea of wiring individual cells in series to vault the voltage-per-cell barrier. Volta subsequently wired his own electrochemical cells into series, which he called piles. Unfortunately, this description of common battery structures is as true today as it was in the 19th century; wiring cells in series remains the only way to boost voltage, at the cost of limiting the battery's overall reliability to that of its weakest cell.

Though the battery landscape hasn't changed much in 200 years, it hasn't been for lack of trying. Since 2009, the Department of Energy's Advanced Research Projects Agency for Energy (Arpa-E) has averaged more than \$350 million in funding per year for investments in hundreds of three-year projects. Experiments thus abound to improve battery technology, but none has yet achieved

energy densities anywhere near the \$50/kWh cost point that would permit widespread commercialization.

In its report for fiscal year 2010, Arpa-E indicates that one of the biggest awards was for a \$7.2 million effort at EaglePicher Technologies LLC (Joplin, Mo.), in cooperation with Pacific Northwest National Laboratory, to develop a planar version of the tubular high-temperature sodium beta battery that would increase that battery technology's reliability and lower its currently high cost for large-scale grid storage applications.

The second biggest award, \$6.9 million, was for another grid-battery project at the Massachusetts Institute of Technology. Called Electroville, the liquid battery technology is designed to buffer usage fluctuations in neighborhoods, much as a bypass capacitor does for printed-circuit boards.

Arizona State University (Tempe), meanwhile, has a \$5 million Arpa-E-funded project under way to perfect metal-air ionic liquid batteries that substitute earth-abundant materials for the rare lithium used in hybrid vehicles today, with a promise to increase the range of electric vehicles to almost 1,000 miles while potentially decreasing the cost compared with those incurred by today's grid-recharged vehicles.

Two other Arpa-E-funded efforts are aimed at improving the performance and lowering the cost of today's state-of-the-art lithium-ion batteries. A \$4 million project at Envia Systems (Hayward, Calif.) aims to increase the energy density of Li-ion from 150 Wh/kg to more than 400 Wh/kg through the use of nanopatterned silicon-carbon electrodes. And a nearly \$2 million project at Inorganic Specialists Inc. (Miamisburg, Ohio) is developing silicon-coated carbon nanofiber paper material that promises to boost the storage capacity of Li-ion batteries fourfold.

None of these efforts, however, hold a candle to the promise of Cambridge Crude, a \$2.5 million Arpa-E funded effort at 24M

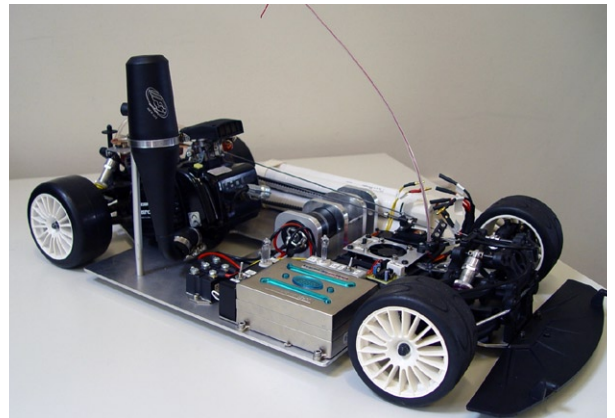

The Fraunhofer Institute for Chemical Technology (Pfinztal, Germany) is developing a flow battery for electric cars.

SOURCE: Fraunhofer

Technologies Inc. (Cambridge, Mass.) to perfect a battery technology for all-electric vehicles that would turn electrons into a fuel that could be pumped like diesel or gas. The ultimate aim is to render gasoline obsolete.

Why now?

Electric vehicles' popularity is tempered today by their limited range, their long recharge times and the poor long-term reliability of their batteries compared with that of internal-combustion engines. Cambridge Crude aims to solve all three problems with a synthetic fuel that can be stored in a tank, comparable in driving-range capacity to gasoline tanks, and pumped at a "gas" station using existing infrastructure. The technology offers reliability rivaling that of internal-combustion engines by moving into the liquid fuel the parts that wear out in batteries.

24M Technologies, a spinoff of nearby Watertown-based A123 Systems Inc., is working feverishly to commercialize Cambridge Crude under the tutelage of MIT professor Yet-Ming Chiang, who founded both companies.

Chiang's aim is nothing less than to reinvent the rechargeable battery through liquid-fuel technology. "Cambridge Crude has a chemical composition designed to simultaneously allow the exchange of lithium ions internally between the cathode and the anode of the battery, and then transfer those electrons to the current collectors and out to an external circuit, where they perform useful electrical work," he said.

In collaboration with MIT and Rutgers University (Newark, N.J.), 24M will use its Arpa-E funding to perfect the basic

Fuel cells relegated to niche apps

Fuel cells were once touted as the made-in-America scalpel that would sever U.S. dependence on foreign oil. General Motors bet big on that promise, investing more than \$1 billion to create fleets of experimental Chevrolet Equinox fuel cell electric vehicles that were tested on the streets of Los Angeles, New York and Washington.

That was three years ago. GM has since shifted gears to the Volt hybrid, which uses a gasoline engine to generate electricity for a motor whose batteries can also be charged with house current (if the owner remembers to plug it in at night).

What happened?

"The infrastructure [for fuel cells] was not evolving fast enough," GM's Britta Gross had said at the time. Gross meant there was no easy way to transform gas stations into hydrogen fueling stations. But you would expect a GM exec whose title was "manager of hydrogen infrastructure" to offer such an answer.

The real reason was that even if you gave away a solar-powered hydrogen fueling station with every electric car, the fuel cells themselves would have become a maintenance night-mare. Their delicate membranes and fatigue-ridden innards were never going to meet consumers' expectations for a 100,000-mile operational life, the bar set by gasoline-powered automobiles.

Battery-powered all-electric vehicles are also destined to disappoint, as early adopters see their gas savings canceled out by the thousands they will need to spend

on replacement lithium battery packs over their vehicles' lifetime.

Cambridge Crude promises to solve those problems by allowing existing gas stations to pump electron-bearing fuels that contain within the liquid all the parts that wear out in a fuel cell.

Nevertheless, fuel cells are finding niche markets that are a good fit. The military, for example, uses fuel cells in the field to recharge battery-powered devices. General Atomics (San Diego) is reportedly saving the Army \$27 million a year—and cutting soldiers' average backpack burden by 10 pounds—with fuel cells that eliminate the need to carry spare batteries; instead, soldiers tote lightweight hydrogen fuel pellets that can be replenished after use with technology invented at Los Alamos National Laboratory. When the fuel cell itself wears out after a few years, the soldier simply throws it away and requisitions another one.

Fuel cells are also proving useful to civilians for recharging batteries while on camping trips and other excursions. SiGNa Chemistry Inc. (New York) offers hydrogen-bearing cartridges, called PowerPucks, that allow pint-sized fuel cells to recharge batteries around the campfire. And since camping trips are few and far between, the short lifetime of the fuel cell itself is not much of a concern, especially for consumers accustomed to a throwaway culture.

Fuel cells are also finding use as methane scrubbers for the atmosphere. For instance,

eBay uses refrigerator-sized fuel cells from Bloom Energy (San Jose, Calif.) to lower its data center's electric bills—an installation of just five Bloom Boxes generates as much power as the 3,000 solar panels on the data center's roof—while simultaneously performing a public service by disposing of methane from a nearby landfill. Other industrial-strength fuel cell installations by



SiGNa Chemistry's PowerPucks are hydrogen-bearing cartridges that allow pint-sized fuel cells to recharge users' batteries during camping trips or on other excursions. Since such trips are generally few and far between, the short life of the fuel cells themselves isn't much of a concern.

Bloom Energy are found at facilities owned by Federal Express, Google, Staples and Walmart.

And Fuel Cell Energy Inc. (Danbury, Conn.) has about 60 fuel-cell installations nationwide, including at facilities owned by Pepperidge Farm and Westin Hotels.

—R. Colin Johnson

liquid-battery technology. The company also recently landed \$10 million in Series A financing from Charles River Ventures and North Bridge Venture Partners (both of Waltham, Mass.) to commercialize its efforts, bringing its total startup funding thus far to around \$16 million.

With that initial funding, 24M promises to produce prototypes that double the energy density at half the cost of lithium-ion batteries, with a goal of 500 Wh/kg energy densities at \$250/kWh for vehicles and \$100/kWh for grid applications.

The company also claims its flow battery design has lower materials and manufacturing costs than the advanced Li-ion batteries made by A123 and even the most efficient

fuel-cell technologies, by virtue of an architecture that does not require cell-based subassemblies or per-unit operations, such as nanoparticle electrode coating, calendaring, slitting, tabbing and module assembly.

24M's core technology was born of Chiang's seminal research at A123, which in turn was inspired by research he conducted at MIT for the Defense Advanced Research Projects Agency. A123 has an equity stake in 24M, a seat on its board and an emerging role in facilitating the development of its technology. A123 will also hedge its bets by continuing to develop its advanced Li-ion batteries, which have a head start in the market but could eventually compete with 24M's more adventuresome approach.

"A123's nanophosphate technology excels in hybrids," said 24M president Throop Wilder, whereas "all-electric vehicles require batteries that are cost-optimized for greater capacity and longer duration.

This is 24M's sweet spot. Because our flow batteries separate power from energy, you build the [reactor] stack where energy extraction takes place for a specific horsepower requirement, then add storage tanks of a size to meet the desired range of the vehicle.

That is the same model the internal-combustion engine uses, where the gasoline tank size determines the range of the vehicle, and the size of the engine how fast you can get there." In a traditional battery, the solid electrolyte that bears the electrons is trapped

inside the battery cells and is released by a chemical reaction at the electrodes. Flow batteries, by contrast, maintain the electrons in a liquid electrolyte that is pumped through a reactor to harvest the electrons.

Thus, instead of recharging, a flow battery merely refills its electrolyte “tank.”

In addition to transcending the 1.5-V limit of traditional battery cells, flow batteries house all the elements that wear out in the solid electrolyte and electrodes of a traditional battery’s cells; only the pumps, sensors and reactor are subject to fatigue and require maintenance. Thus, long-term reliability is greatly enhanced.

Also, because it separates the battery capacity (tank size) from the power output (reactor size), the flow battery can be scaled for nearly any application, from micron-sized units for mobile devices to decametersized versions for municipal power stations.

DOE-funded projects have already produced flow batteries based on a variety of aqueous chemistries, such as vanadium redox and zinc halogen systems. All of these efforts, however, have energy density limitations that prevent them from meeting electric vehicle requirements, according to 24M. The company claims to have created the first “semi-solid” flow battery design, in which the electrodes store as much as 10 times the energy of aqueous chemistries by using liquid suspensions of the solid active materials used in lithium ion batteries, such as lithium-cobalt-oxide powder, along with nanoscale electroconductive carbons suspended in an alkyl carbonate electrolyte. The nanoscale carbon particles spontaneously form a conductive network in the fluid, providing a direct pathway for electrons

to reach the batteries’ current-collecting electrodes.

24M also claims that by using fluids of much higher energy density than aqueous chemistries, it can produce a more cost-competitive flow battery system for gridscale storage.

The official name for the Cambridge Crude technology is the semi-solid flow cell (SSFC), because of the high viscosity of the liquid and its similarity, in some respects, to fuel cells. SSFCs aim to combine the high energy density of rechargeable batteries with the scalability of fuel cells and the longevity of flow batteries. Although 24M is holding back many of the details of its process to avoid tipping off competitors before commercialization, the underlying principle of SSFCs is to store the liquid charge-transfer compounds in suspensions of solid storage compounds that are sufficiently dilute to percolate through networks of nanoscale anodes and cathodes.

One disadvantage of SSFCs compared with traditional batteries is that they rely on a complex system of mechanical pumps, sensors and control units that move the Cambridge Crude from the “gas tank” to a secondary containment vessel for spent fuel.

Also, the energy densities of flow batteries in general have been much lower than that of high-performance Li-ion battery packs, and thus far even 24M’s most advanced prototypes are no exception. The startup also admits that the electrical conductivity of the spontaneously forming carbon nanoparticle networks needs to be improved a hundred-fold to foster widespread adoption.

But 24M claims to have seminal technologies in the works that will solve all of Cambridge Crude’s shortcomings over the next five years.

The company says the advantages of SSFCs make them worth the risk for 24M’s investors. It claims to have solved the longevity problems that nixed General Motors’ foiled billion-dollar effort to develop automotive fuel cells (see framed article page 18) with a technol-

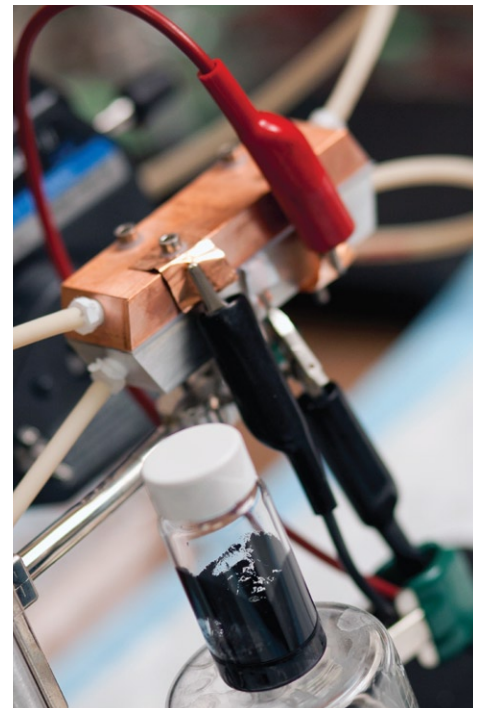

Cambridge Crude (in bottle) is a liquid electrolyte that flows through a reactor, where a copper electrode (top) and an aluminium electrode (bottom) extract electrons to power an electric motor or any other dc load. The reactor draws the electrons as they blow through its center. The nanoscale carbon particles in the liquid complete the circuit between the Cu and Al collectors.

SOURCE: MIT

ogy that offers twice the energy density of traditional batteries and 10 times the energy density of competing flow battery designs.

For instance, SSFCs separate the power-producing and energy-storage components, allowing each to be scaled separately for specific applications. Also, SSFCs’ life cycle will be longer than those of all currently competing technologies, because SSFCs don’t rely on solid-phase changes that can fatigue.

Further, their architecture does not require subdivision into cells, whereas conventional batteries must be divided into multiple 1.5-V cells.

SSFCs reportedly retain the good characteristics of traditional batteries, fuel cells and other flow battery designs. Like Li-ion batteries, SSFCs have a quick response time; like fuel cells, they release no harmful emissions into the environment; and like other flow battery designs, they can be scaled in size to suit apps from mobile devices to power generation utilities.

24M plans to work with A123 to bring out advanced commercial SSFC designs for those two markets at opposite ends of the size spectrum, and various others in between. ■

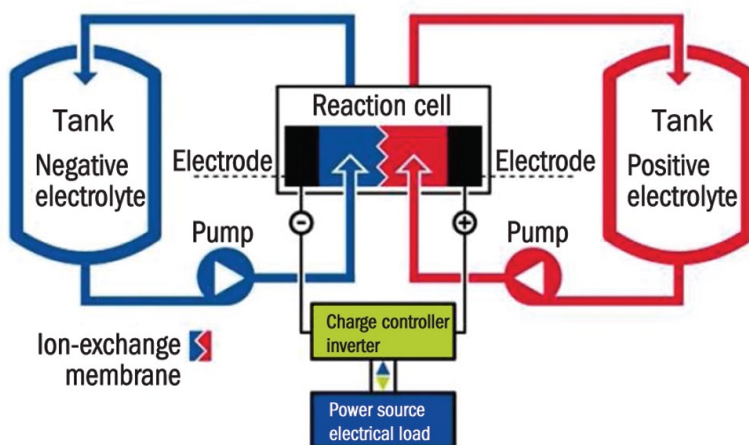

EcoVoltz Inc. (San Jose, Calif.) is developing a flow battery for which the target market is large power generating facilities, such as wind farms. SOURCE: EcoVoltz

Pro audio techniques applied in mobile devices to improve sound quality

SPECIAL FOCUS:
ANALOG & MIXED SIGNAL

By Earl Schreyer

WHILE MOBILE PHONES continue to emerge as a key communications device and become more feature rich with multimedia applications, there still remains the challenge of achieving good sound quality from the small low profile speakers. Pro Audio techniques such as Dynamic Range Compression (DRC) and limiting can be designed in and applied to the speaker amplifying device to improve the user experience.

DRC and limiting are traditional recording and broadcasting techniques used to raise the volume of subtle audio (such as human voice), in order to bring out those nuances, but at the same time automatically attenuate the dynamic peaks as not to overload the level. This technique is also used on the final mix in recording to increase the average level of the entire track without overloading during louder passages.

In addition, the use of compressors to boost perceived volume is used by broadcasters who want their station to 'jump out' at the same volume as comparable stations on the dial. This can also be useful for "in-car" listening to compensate for natural vehicle and road background noise.

In common to all the above applications, if the lower level amplitudes can be raised while the higher level peaks are attenuated; the overall volume can be increased without distorting and over loading the electrical level or the speakers on the louder dynamics of the audio. This article describes how these techniques can be applied and how they can aid in improving communication as well as

Earl Schreyer has 20 years experience in designing integrated circuits. He began his career with Fairchild Semiconductor in 1999 joining the analog & mixed signal products group, building on analog and high speed ADC work in the application of video/graphics digitizers and continues time video filter drivers. He has a passion for audio design and has recently become a key member in the new mobile audio group.

entertainment in modern mobile devices. Compression and limiting have been around for a long time. In 1959 Sherman Fairchild licensed a compressor/limiter designed by Rein Norma giving life to the legendary Fairchild 670 compressor/limiter. The Fairchild 670 has found its way onto many classic recordings over the years including famous Beatles recordings at Abbey Road Studios in the 60's. The unit is still revered to this day, can go for upwards of \$30,000 in good condition, and many software plug-ins have been designed to emulate its tone and function. This unit was all hand wired, had over 20 vacuum tubes, 14 transformers and weighed in at a hefty 65 pounds – see figure 1. Mr. Fairchild couldn't have known that over 50 years later, Fairchild Semiconductor would be integrating dynamic range compression/limiting, as well as I-W Class-D amplifiers, and stereo Class-G headphone amplifiers on to a single silicon die roughly 2mm on a side.

Dynamic range compression and limiting can be useful in mobile devices with speaker amplifiers to raise the average level of the audio output (turn it up) while compressing or limiting the louder peaks of the signal to reduce distortion and speaker overload. A compressor is essentially an automatic gain control. Loud sounds above a certain threshold are automatically turned down while quiet signals are unaffected. The dynamic range of a system is defined as the largest signal the system can handle linearly



Figure 1: 1959 Fairchild 670 compressor.

divided by the smallest signal it can process (or the noise floor lower limit). Therefore, the effect is technically compressing the dynamic range of the system because it is attenuating the higher peaks as compared to the lower level signals. However this is desirable in certain situations to raise the lower level signals.

Compression therefore has the potential to improve audibility in a mobile phone conversation. In addition, for entertainment such as audio tracks for video, it allows the smaller speakers to bring out the more subtle parts, but not overload on the louder dynamics for a better user experience. A compressor reduces the level of an audio

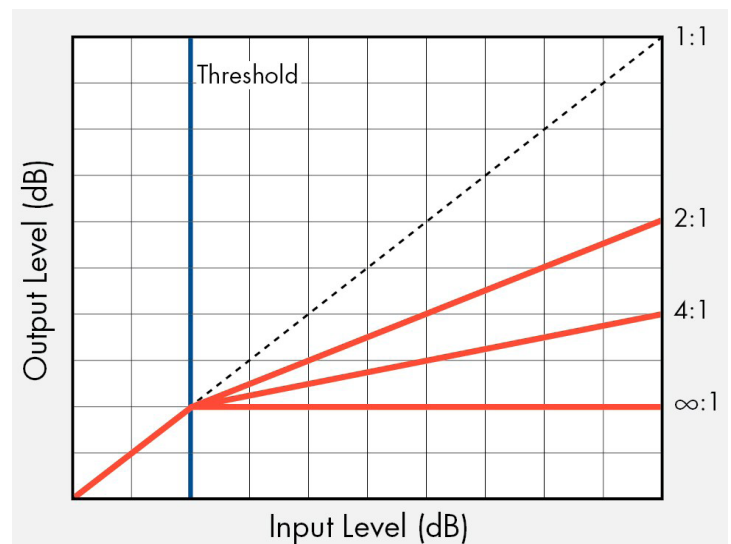

Figure 2: Generic compression ratio curves. (Wikipedia 2011)

370,000 Miles + 17 Field Tests = 1 Protocol

We've Gone the Extra Mile to Make G3-PLC a Global Standard



Maxim has partnered with multiple utilities and meter vendors to test G3-PLC™ in powerline networks around the world. The result? A single, field-proven protocol that meets global smart grid requirements. G3-PLC's advanced OFDM techniques and built-in robustness mechanisms enable fast data rates over long distances, making it ideal for real-time energy management in large-scale networks.

G3-PLC Benefits

- Long-distance communication over medium-voltage lines saves the expense of multiple repeaters
- Communication across medium-to-low-voltage transformers enables more users to be connected to each concentrator
- Conformance with emerging international standards (IEEE P1901.2, ITU G.9955, IEC/CENELEC) protects infrastructure investments and allows sourcing from multiple vendors



Order an evaluation kit and discover why the world's leading utilities rely on G3-PLC.

Order your reference design today.
www.maxim-ic.com/PLC-Kit

MAXIM
INNOVATION DELIVERED®

MAXIM DIRECT
www.maxim-ic.com/shop

AVNET Memec
www.avnet-memec.eu

SILICA
An Avnet Company
www.silica.com

For a complete list of Maxim's sales offices and franchised distributors, visit www.maxim-ic.com/sales.

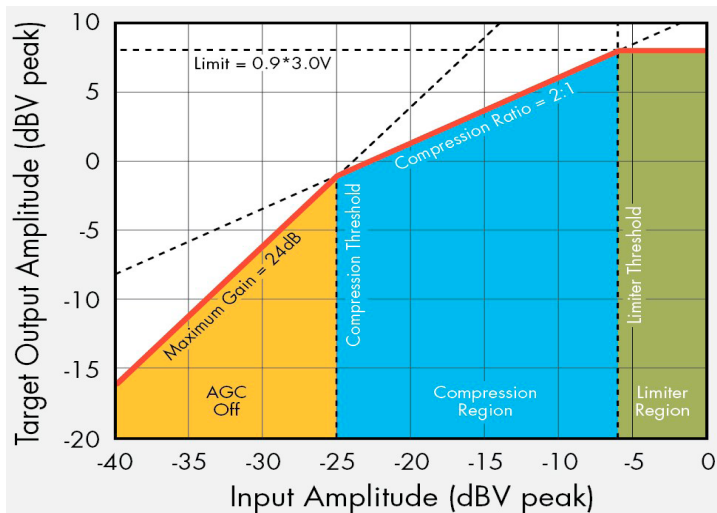

Figure 3: Using compression and limiting together (using a Fairchild audio subsystem).

signal if its amplitude exceeds a certain threshold. The amount of gain reduction is determined by a ratio; a ratio of 4:1 for example means that if the input level is 4 dB over the threshold, the output signal level will be reduced to 1 dB over the threshold. The gain (level) has been reduced by 3dB.

Compression and limiting

Figure 2 below shows an example of compression response curves for 2:1, 4:1, and infinity:1 (limiting). This demonstrates that, below the DRC threshold, the output vs. input has a fixed gain response. After the DRC threshold is crossed, the gain changes proportional to how far above the DRC threshold the original signal would have gone. Following that, it becomes clear what amount of compression will be applied for the given compression ratios as described above. The engineer can then increase the system gain to bring out the lower levels of the audio, while compressing the potentially distorting or overloading signals. You may hear the term “normalizing” the gain, where the engineer re-adjusts the system gain so that the highest levels (peaks) are synchronized to the same level as they were without the effect enabled, but now the lower amplitude signals below the DRC threshold will be boosted.

As compression ratios are further increased (above more than 10:1 for example), the effect starts to become what is called a ‘limiter’. In this case, the automatic gain control will continue to decrease the gain such that the output amplitude will no longer be allowed to increase any further after the DRC threshold is crossed. In mobile devices it can be useful to implement both techniques together. You could think of the compression region as

will decrease along with the battery voltage to prevent distortion as the battery voltage naturally decays. With Figure 3 you can see an example of the two effects working together for a combined response. In addition, with this setting, the initial gain is 24dB, and when the DRC threshold is crossed the circuit response moves to a 2:1 compression region. Finally, if the output signal would have peaks over 90% of the battery voltage, the output gain will be reduced further so that the output signal level cannot go above the limiter level. Then this limiter level would continue to move down as the battery voltage decreases since its value is always $0.9 \times V_{batt}$. Compressors are also often supplied with attack and release times to control the speed at which the circuit operates on the signal. Usually it’s desirable to attack down on the peaks rather quickly as not to overload and distort the speakers, and then allow the effect to release slowly as the envelope of the audio signal stays below the threshold level. Figure 4 shows an example of attack and release times. The signal is shown as a pulse to clearly illustrate the attack and release times. Again for illustration purposes, the attack time is shown just slightly faster than the release time. These controls can be used to tailor the effect for the given

a gradual approach to limiting, and if a higher final limiting level is reached, the limiter will kick in and prevent the signal from increasing any further at the output. Limiting can be useful in mobile devices to track the battery voltage. For example, if the limiting threshold tracks (is proportional to) the battery voltage, the limiter level

application to optimize its usefulness. For example, a phone conversation may have different settings than playing music, or different instruments in a studio recording environment may have different settings to tailor the effect to that given instrument. Since Fairchild audio subsystems have high-resolution digital volume controls, the gain can dynamically be controlled within the device to approximate the ideal compression ratio curves and limiting response when threshold levels are sensed internally to the device. These devices have on-board trimmed oscillators, so a very accurate time base can be applied to create programmable attack and release times for the DRC and limiting features.

New Fairchild mobile audio subsystem ICs on the market and soon-to-be-released products incorporate both fixed THD limiting as well as battery voltage scaled limiting, while others include fixed THD limiting, battery scaled limiting as well as dynamic range compression. Furthermore, boosted stand-alone class-D speaker amps from Fairchild incorporate limiting as well.

With the small low-profile speakers in today’s mobile devices, these traditional Pro Audio techniques can be used to raise the lower level audio signals in a conversation to aid in communication (so you don’t miss what the person is saying). Taking advantage of the multimedia entertainment features, compression and limiting can also be applied to maximize the audio level for listening pleasure (for a movie or video for example) while not allowing the louder dynamics to reach an unpleasant and potentially speaker damaging level. ■

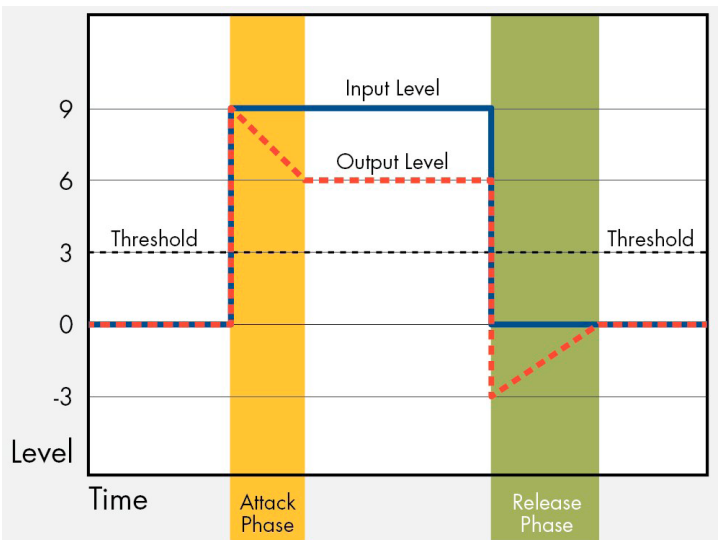

Figure 4: Attack and release times. (Wikipedia 2011)

Haptics technology: picking up good vibrations

By Eric Siegel

IF YOU'VE EVER touched a cellular phone, there's a good chance you've been exposed to haptics. Before you start reaching for the hand sanitizer and calling your doctor (it'd be a bit late for anything at this point anyway, don't you think?), know that the only infectious thing about haptics is its amazing ability to take gameplay, touch screen devices, and portable electronic user experiences to an entirely different level. Why in the world would someone call such a cool, enabling technology like haptics such a weird word? It's all Greek to me...literally. Haptics comes from the Greek word "απτο" which means "I fasten onto, I touch." Basically, a Haptics enabled system is any system that incorporates feedback via vibrations through the sense of touch. After the Greeks invented the word, not much happened with it until modern times, where Haptic technology has manifested itself in a multitude of industries.

First applications were seen in aviation to allow pilots to "feel" simulated vibrations in the stick when stalling out was imminent. In older aircraft, this vibration occurred naturally but due to improvements in control systems it had to be detected and the feedback was forced into the system. Over the years, Haptic systems have spread to simulation and electronic environments. Devices that allow a user to sense and feel objects in a remote (or virtual) environment have been used in excavation, building design, education, and even remote medicine. On a more personal level, Haptics is the reason you can (or at least should be able to) enjoy silence at the movies and still get reminded of that meeting you "forgot" about, or get that text message saying you won the lottery (why you'd be text messaged that I don't know), and not alert your neighbours. In the gaming world, Haptics lets you know when your car is starting to veer off the road or when you are taking damage in a Halo

Eric Siegel is a product marketing engineer for touch screen controllers and haptics drivers at Texas Instruments - www.ti.com

grudge match, due to the embedded actuator in your controller and the programming in the game that utilizes it.

But enough about how meaningful it is to you, let's talk about how it works. In essence, there are really two types of Haptic actuator technologies in the market today. One is old school and one is new school, but both are essentially motor-based. Each topology has its own pros and cons and unique offerings. Let's take a closer look at each one.

Eccentric rotating mass (ERM) – old school

The Eccentric Rotating Mass is the oldest and most mature Haptic technology in the market. When you think of any vibration-enabled device from yours, the vibrations were most likely caused by an ERM. As pictured in figure 1, ERMs are comprised of an off-centre rotating mass which, as it spins, creates an omni-directional vibration which propagates throughout the entire device, like the vibration alerts you get when your cell phone is on silent or vibrate mode.

Unfortunately, due to the construction of the ERM, the ability to create sophisticated wave profiles is limited. The frequency and amplitude of each wave is coupled together to the input-control voltage,

Eccentric Rotating Mass

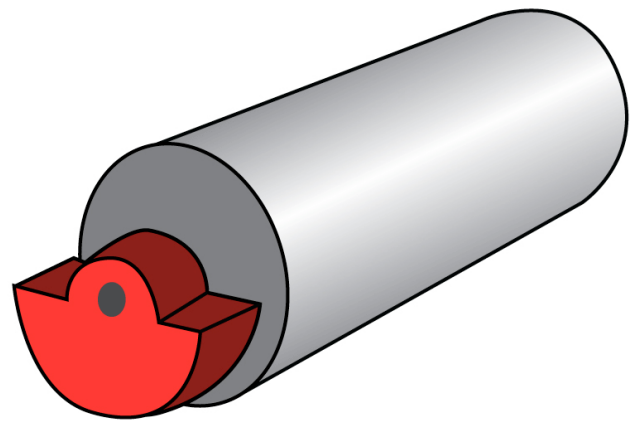

Figure 1: The construction of the eccentric rotating mass (ERM) haptic actuator.

leaving you only one variable to play with to create different effects. Generally, you're only able to create different combination of pulsing or speed, not too far removed from the dots and dashes of Morse code. Along those same lines, getting the motor up and running and subsequently stopping it creates a bottleneck compared to newer technologies, making the ERM one of the slower options when it comes to speed and response time. However, one good thing about the technology is that since it has been around for so long, it's one of the more cost-efficient options available.

Linear Resonant Actuator

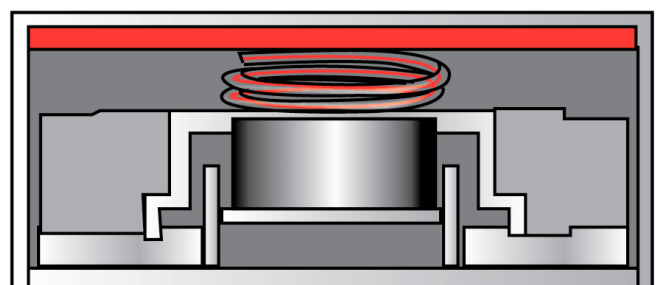

Figure 2: The linear resonant actuator (LRA) haptic actuator.

Linear resonant actuator (LRA) – new school

The next leap in Haptic technology is the Linear Resonant Actuator, which has become very popular with a lot of new handset companies. The LRA is a magnet attached to a spring, surrounded by a coil and housed in a casing – see figure 2. The magnet is manipulated and moves in a linear fashion and eventually is brought up to the resonant frequency. This operation at the resonant frequency allows the driver to operate at a lower power-consumption rate, about 30% better than the ERM; however, you are locked in on that frequency. Efficiency and performance drop off considerably as the LRA's drive frequency moves outside of that resonant band. This can be a design concern, because the spring constant can change due to wear and tear, temperature fluctuations, or other environmental factors such as if the LRA's device is being gripped or not (though if it's not being gripped, you probably won't care about a lack in performance.)

Although you may be locked in terms of frequency, you can modulate the amplitude of the input signal that's being sent out, to add an extra degree of freedom and unique waveform profiles that you can't achieve with an ERM. With respect to response time, LRAs have a leg up on ERMs, as they can be used to keep up with entering multiple letters per second for button confirmation, making them well suited for texting or any sort of typing application on a handset. We've covered both old and new school in terms of haptics actuators, but there still remains one more actuator that I haven't covered. This type of actuator is not motor based, has incredible response time, is energy-efficient, and is much smaller than both the ERM and LRA. These fabulous new devices are known as piezo actuators.

Piezo actuators

Piezos aren't exactly a cutting-edge technology; they've been around for decades and consist of a film that acts as a transducer between vibration and voltage. Previously, they have been used in energy-harvesting applications and for driving speakers, but have added a new line in their resume by giving you the most sophisticated haptics experience available. The standard piezo actuator technology involves either a thin strip or a round disk that goes from flat to bent and back, creating vibrations by applying a voltage across the ends – see figure 3. One setup with the strips includes fixing the piezo strip

ends to the touch screen itself and then attaching the center of the strip to the case of the device. The touch screen then is housed in a case where it can “float,” allowing piezo vibrations to be felt predominantly on the screen. This experience is known as “localized haptics.” You will still feel some vibrations in the device itself but the majority is felt on the screen only. If the floating screen is forgone, another topology exists as a drop-in module. This will give similar but reduced functionality: the level of sophistication is not quite as high as localized haptics, but it does reduce design complexity by a significant amount.

Piezo-based haptics are not bound by any frequency or amplitude constraints, allowing the designer to create wave profiles not attainable by LRAs and ERMs. For example, though you could not replicate the exact tactile feedback felt from pushing a mechanical button, with piezo-based haptics you can come extremely close. With multiple piezo modules embedded in a design, one can create a high definition haptics experience, allowing individual sections of the touch screen to vibrate. In the case of a capacitive touch driven application, each touch point (finger) could feel its own unique wave response rather than the entire screen shaking. One drawback to piezo-based actuators is that most systems require around 100-200 Volts peak-to-peak (Vp-p) to be driven through the device. Multiple-layer piezo actuators can reduce that system voltage down to 50 Vp-p, but these multiple-layer piezo actuators can get costly. From a speed and response-time perspective, look at figure 4. ERMs and LRAs run in the 30-60 millisecond range, whereas piezo actuator response times run typically less than 2 milliseconds. This attribute makes them extremely power efficient compared to ERMs and LRAs. With piezos, while you can get up to speed, run your waveform and go back to stasis faster, you'll also be using less

energy. As cool as these actuators are, they're only one component in the whole mix. There are many other products contributing to the actuator's “greatness.” One component directly behind the actuator is the physical driver. There are many on the market, but only a few are specifically designed for piezo actuator driving. For example, TI's DRV8662 is a 200-Vp-p piezo haptics driver with an integrated boost converter. With a fast start-up time of 1.5 ms, this piezo driver is versatile and ready for whatever high-end piezo haptics system you are designing. The input voltage can be single ended or differential, and is useable with a 3.0-5.5V power supply. All this value in a small package means you can use less board space and reduce your overall system cost, thanks to the lack of a transformer due to the integrated power switch and diode. Piezo haptics is a game-changer for today's current haptics implementations, and can help ensure your customers are getting the fullest, richest user experience possible. ■

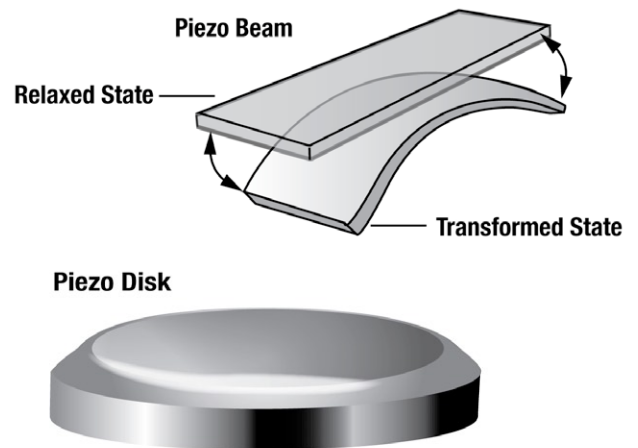

Figure 3: Piezo haptics actuators usually involve either a thin strip (a) or flat disk (b) that creates vibrations when a voltage is applied.

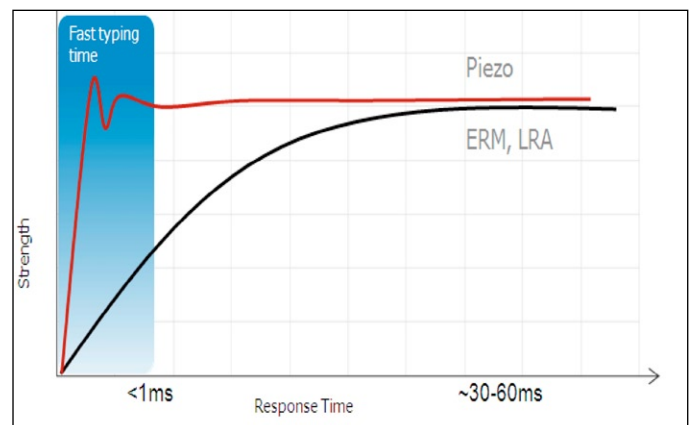

Figure 4: Piezo haptics technology possesses significantly faster start-up times than either ERM and LRA technology.

**SPECIAL FOCUS:
ANALOG & MIXED SIGNAL**

Digital variable gain amp
for basestation radio architectures

National Semiconductor has introduced a pair of quad- and dual-channel, digital variable gain amplifiers (DVGA) that enable high-



er-performance wideband radio systems. The LMH6522 quad and LMH6521 dual DVGAs are optimized for driving a wide range of load impedances. Their low-Z output drive delivers exceptional signal fidelity and provides

the additional power gain needed when driving low impedance filters. The devices are well-suited for driving high-speed ADCs, including National's ADC16DV160 dual 16-bit, 160 MSPS converter. In addition, the LMH6521 is ideal for driving National's ultra-high-speed ADC12D500/800RF 12-bit, 500 MSPS/800 MSPS direct RF-sampling ADCs. By adding the LMX2541 frequency synthesizer and one of National's family of LMK04800 or LMK04000 clock jitter cleaners, a designer can form a complete signal path.

National Semiconductor

www.national.com

Low voltage comparators
single or dual, operate from 1.6 to 5.5V

The FAN156 and FAN256 from Fairchild Semiconductor are low power comparators that typically consume less than 10 μ A of supply current. They are guaranteed to operate at a low voltage of 1.6 V and are fully



operational up to 5.5 V, making them well suited for use in 1.8, 3.0 and 5.0V systems.

In mobile applications, the FAN156 and FAN256 help reduce the 3-times falling issue associated with slow insertion of an audio headset jack, as well as enable different audio headset jacks to be used in the same device. Both devices feature a complementary push-pull P and N-channel output stage capable of driving a rail-to-rail output swing with a load ranging up to 5.0 mA.

Fairchild Semiconductor

www.fairchildsemi.com

GaAs broadband push-pull amplifier

M/A-COM Technology Solutions introduced a new GaAs broadband push-pull CATV amplifier featuring a 20.5 dB gain. Packaged in a 4mm QFN, 20-lead plastic package, the MAAM-009455 is a highly linear amplifier, with low noise figure and

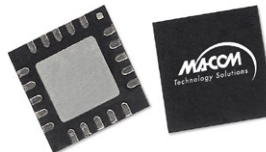

power dissipation. The MAAM-009455 exhibits an excellent gain flatness of 0.5 dB typical over the 50 to 1000 MHz operating band. Input return loss has been optimized to achieve better than 20 dB across the band.

M/A-COM Technology Solutions

www.macomtech.com

POWER

smarter, faster, smaller

At CUI, our approach is to develop smarter, faster, smaller power modules. Whether it's an embedded ac-dc power supply, a board level dc-dc converter, or a level V external adapter, we continuously strive to keep our power line, that ranges from 0.25 W to 2400 W, ahead of the curve.

Check out the latest addition to CUI's power line:
720 W Novum Intermediate Bus Converter

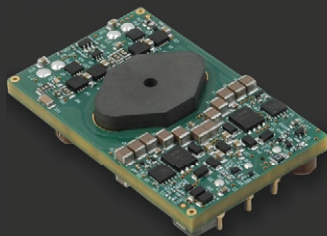

NQB2 1/4 Brick IBC Converter

Highlights

- Industry leading power density
- Driven by CUI's patented Solus™ Power Topology
- DOSA compliant pin-out

Specifications

- 720 W / 60 A output
- 1/4 brick package
- 36-60 Vdc input range
- Up to 96.4% efficiency

solus
A CUI TOPOLOGY

cui.com/power



XpressO XO HCMOS oscillators

tight stability, 0.75 to 180MHz range

Fox Electronics now offers a 2.5-volt version of its compact XpressO XO HCMOS oscillators. The FXO-HC32 series joins the extended XpressO family as a 2.5-volt version of the 3.2x2.5mm package oscillators, offering stabilities as tight as ± 25 ppm and a wide frequency range of 0.75 to 180MHz.

With the ability to operate in a temperature range of -20 to +70°C or -40 to +85°C and available frequency resolution to six decimal places, the versatile and precise 2.5-volt FXO-HC32 XpressO oscillators are suitable for applications that require low jitter in a very compact, cost-effective package. XpressO

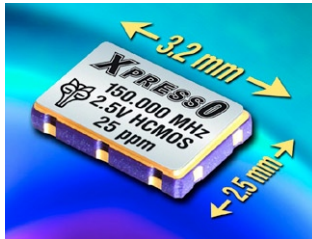

crystal oscillators use a family of proprietary ASICs, designed and developed by Fox with a focus on noise reduction. These ASICs enable users to select the

optimum combination of output type, input voltages and temperature performance features. XpressO oscillators have reduced noise levels comparable to traditional bulk

quartz and SAW oscillators by using the third order Delta Sigma Modulator (DSM). The low cost oscillators also offer extremely low jitter, less than 1ps. Samples are available in one to two days and within 10 days for production quantities.

Fox Electronics

www.foxonline.com

Voice and M2M connectivity

in low-power communications chipset

Silicon Laboratories announced the next generation of its Si24xx ISModem family, offering advanced voice features, lower power, reduced BOM costs and flexible interface options for a wide range of data modem applications. When combined with Silicon Labs' popular Si3000 voice codec, the Si24xx data modems support handset, speakerphone (full or half-duplex), voice menu and answering machine implementations.

Developers can easily add telephony and voice functions to any embedded system, without the need for the dedicated voice processing ICs or host-based DSP software required by legacy approaches. The voice-capable

Si24xx ICs are suitable for any system with telephony functions ranging from POS terminals and security systems to video phones and medical monitoring equipment.

In addition to offering a complete suite of ITU-T "V-dot" data communications, compression and error correction protocols, the ISModem family

supports specialized protocols used in security and POS applications. Operating from a single 3.3 V power supply, ISModem chipsets draw 56 mW in normal operation. Sleep and Wake-On-Ring (WOR) modes are available, drawing 0.3 and 15 mW, respectively.

Silicon Laboratories

www.silabs.com

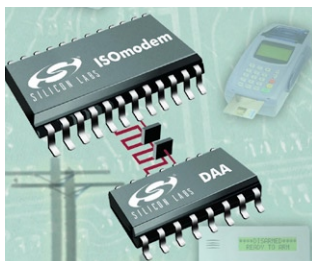

5V zero drift rail-to-rail Op Amp

offers low power consumption with half the noise

Intersil Corporation has extended its family of precision op amps, introducing a new 5 V, ultra-low noise, chopper-stabilized zero drift rail-to-rail amplifier

featuring half the noise of competitive amps that consume similar power. The ISL28134 is a design choice for

amplifying small signals in analog front ends that interface to pressure, temperature, medical, strain gage and inertial sensors. The device is also well suited for low noise instrumentation systems by providing amplification before 24-bit delta sigma

ADCs. The chip features a noise voltage of only 0.25 microVpp from 0.1Hz to 10Hz, an ultra-low offset voltage of 2.5 microV maximum and a drift of 15 nV/

°C maximum. Operating current consumption is only 675 microA. Rail-to-rail input/output capability maximizes signal levels

and a CMRR of 135 dB minimizes errors in differential input configurations. The ISL28134 is available now in an 8-pin SOIC package.

Intersil Corporation

www.intersil.com



Haptics controller chip

for enhanced display tactile feedback

HiWave Technologies launched its first haptics controller integrated circuit for use with the company's haptic exciters to deliver real-time touch feedback to users' fingertips. The HIHS9002 uses the company's patented bending wave technology to create and position tactile sensations on conventional flat panels. The chip has extremely low latency when receiving coordinates and vectors from a host system processor and delivering stored haptic signals to the transducers.

The timing of the tactile response, with reference to the user's anticipation of mechanical feedback, is critical to the successful deployment of haptics. HiWave's signal library comprises a range of haptic clicks and textures that allow straightforward implementation of button, trackpad and scroll features. In

addition, it contains audio cues that can be delivered through the same transducers, which turn the flat panel or display into a loudspeaker. Multiple haptic signals and audio cues are stored in the chip's non-volatile memory, enabling appropriate feedback to be generated to accompany the

key-press or gesture being invoked by the user. HiWave's real-time rendering algorithms are fundamental to the implementation of bending wave

haptics and are embedded in the controller. One of their key functions is to compensate in advance for the signal dispersion and interference that occurs between the actuators and the point of finger contact. The HIHS9002 comes in 48 pin LQFP and 64 pin BGA packages.

HiWave Technologies

www.hi-wave.com



SPECIAL FOCUS: ANALOG & MIXED SIGNAL

48-channel PWM generator

with 12-bit resolution dynamically controls LEDs

Linear Technology has released a pulse width modulation (PWM) generator with 48 independent channels. Each channel has an individually adjustable 12-bit (4,096 steps) PWM register and a 6-bit (64 step) $\pm 50\%$ correction register. All controls are program-

mable via a simple TTL/CMOS 50 MHz serial data interface. The LT8500 can be used in a wide variety of PWM-intensive applications such as LED control, as well as industrial and robotic applications. For example, the LT8500 can be used with three LT3595As, 16-channel LED drivers, to deliver 48-independently dimmed LED strings for locally dimmed LED backlighting for large LCD displays. The correction resistor allows matching light output of each LED string. The LT8500 operates from a 3 to 5.5V input range, enabling it to operate from a wide range of standard power buses. For LED

applications, each channel has individual 6-bit dot correction current adjustment and 12-bit gray scale PWM dimming. The 40 ns on-time of the LT8500 offers wide dynamic contrast ratios. Both correction and gray scale dim-

ming are accessible via a serial interface in TTL/CMOS logic. The LT8500 offers two diagnostic information flags: synchronization error and open LED. The flags are sent with additional state information, on the serial data interface during status read back. The 50 MHz cascadable serial data interface includes buffering and skew-balancing for PWM-intensive applications such as large screen LCD dynamic backlighting. The chip comes in a 56-lead 5x9mm QFN package.

Linear Technology

www.linear.com

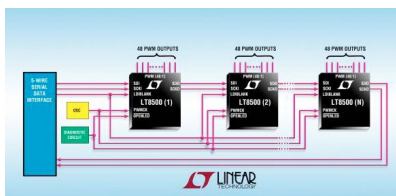

Fully integrated ADC

targets portable equipment

Texas Instruments has announced the ADS1118, a 16bit Delta-Sigma ADC that integrates a programmable gain amplifier, reference, temperature sensor and 4-input multiplexer, and which, TI claims, is more than 65 percent smaller than any other ADC available today. It provides direct, linearised measurements with uncalibrated error guaranteed below 0.5°C from 0 to 65°C; claiming a 75 percent improvement over its competition. The company also claims this is the lowest power 16bit ADC with a built-in internal reference, supporting data rates up to 860 samples/s. TI is

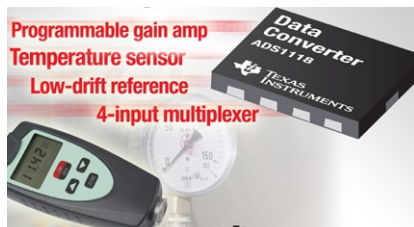

providing a number of tools and support for the device, including an IBIS model, anti-aliasing filter tool for data converters and op amp to ADC circuit topography calculator. Engineers can also ask questions and help solve problems in the precision data converter forum in the TI E2E Community.

Texas Instruments

www.ti.com

Digital audio SoC family

enables cooler new flat-panel TV designs

STMicroelectronics has released two new Sound Terminal digital-audio system-on-chip ICs for home-entertainment applications, which will enable smaller new-product designs while also running cooler to help designers meet tough product-safety requirements.

Home-entertainment innovations such as flat-panel TVs and music docks enable consumers to enjoy room-filling audio without needing a roomful of audio equipment. ST's Sound Terminal system-on-chip ICs have taken a leading role in enabling new generations of smaller, slimmer products by combining digital audio processing, speaker drivers and other functions on a single chip. The 48-pin VQFN 7x7x1mm STA381BW and STA381BWS are optimized for flat-panel TVs and enable

designers to reduce pc-board sizes further by consolidating a headphone driver, line-driver output, and an independent digital-to-analog converter (DAC). The integrated DAC provides an extra analog output that can be connected to the headphone input or to an external circuit, and uses ST's F3X technology to simplify external filtering. The headphone driver and industry-standard 2Vpp line out, which require no DC blocking capacitors, also save external components and hence maximize reductions in pc-board size and manufacturing costs. The STA381BW and STA381BWS deliver best-in-class thermal performance through high energy efficiency, proprietary ternary PWM modulation and enhanced package design.

STMicroelectronics

www.st.com



800 to 1600MHz TO-8 VCO

hermetically sealed

Crystek has introduced the CVCOT8BE-0800-1600 TO-8 VCO (Voltage Controlled Oscillator) which operates from 800 MHz to 1600 MHz and provides high-performance frequency control in harsh, demanding environments. The VCOs feature a typical phase noise of

-92 dBc/Hz at 10kHz offset and excellent linearity. Tuning sensitivity is rated at 79 MHz/V. Pulling and Pushing are minimized to 20.0 MHz and 4.0 MHz/V, respectively; second harmonic suppression is -10 dBc typical. The CVCOT8BE line features a full-functioning VCO

in a rugged, hermetically sealed TO-8 package to protect the VCO from moisture, contaminants and other elements. The metal-can construction features

gold plated pins with no internal wire bonds for enhanced signal integrity. Further, the VCO features a control voltage range of 0

V to 20 V with an input voltage of 15 V. Maximum current consumption is 20 mA and output power is +10 dBm. The TO-8 VCO line has an operating temperature range of -40 to +85°C.

Crystek

www.crystek.com



Booster amplifiers

2 to 2.8GHz for CoFDM video and outside broadcast

Bristol-based amplifier design specialist, Amplifier Technology has developed a new range of communications amplifiers for the broadcast market - the 8800 and 8801 COFDM linear amplifiers, which are nominally rated at 1 watt and 5 watts respectively. Both amplifiers operate at between 2.0 GHz and 2.8 GHz for video at QPSK, 16QAM and 64QAM modulation schemes, which makes them ideally suited

for outside broadcast applications, for example for use with wireless cameras. The 1-W amplifier, model 8800, measures 110x60mm, while the 5-W amplifier, model 8801, is slightly larger, at 155x115mm. Both are easily portable via a 12V supply. Test results show good linearity across the band.

Amplifier Technology

www.amplifiertechnology.com

Portable audio subsystem

with integrated programmable clock generator

Integrated Device Technology has released what the company claims is the world's first audio subsystem with integrated programmable clock generator for portable applications. The new device minimizes board space and reduces system cost through integration, and provides time-to-market advantages by eliminating the need for multiple external crystals and oscillators that typically involve long lead times. The ACS42200 family includes a low-power, high-fidelity codec targeted at portable applications such as tablet comput-

ers, portable games, personal navigation devices, portable projectors and speaker docks. The device also integrates four programmable system PLLs for internal and external timing, a DDX class-D speaker amplifier, a true cap-less headphone amplifier, and advanced built-in audio processing capability for 3D, bass and treble enhancement. The four integrated programmable system PLLs are unique to IDT's codec solution and enable the timing management of a system's applications proces-

sor, USB interface, secondary audio and other subsystems. This allows system designers to eliminate large, costly crystals and oscillators that can often cause procurement delays, while the integrated spread spectrum capability can eliminate EMI concerns. In addition, IDT's patented DDX class-D technology offers higher efficiency, consuming less power than traditional binary class-D solutions. This results in a significant improvement in battery life – a critical demand of next generation portable consumer electronics.

All of the features are further complemented by a programmable DSP filter engine that enriches the sound presence through dynamics processing, equalization, speaker protection, and louder volume when using small speakers. IDT also offers complete driver support and tuning tools for faster time-to-market with Linux and Android systems, and flexibility in speaker selection and industrial design.

Integrated Device Technology

www.IDT.com



LED driver reduces complexity

and cost in automotive lighting apps

Micrel has rolled out the MAQ3203, an AEC-Q100 version of the MIC3203. This step-down High Brightness LED (HBLED) driver IC reduces the complexity and cost of high current LED driver solutions in automotive lighting applications. The MAQ3203 is capable of driving multiple HBLEDs in series at more than 90 percent efficiency with 5 percent current accuracy from input voltages of 4.5 to 42V. With its hysteretic control architecture and high-side current sense scheme, the device provides an ideal solution to drive the HBLEDs with constant current. The operating frequency is adjustable up to 1.5 MHz which allows flexibility in the design and offers a frequency dithering feature to mitigate EMI. The IC features a dedicated PWM dimming pin, an enable pin for very low power shutdown, over

temperature protection and an under voltage lockout. The MAQ3203 has an external power switch and requires no external compensation.

“LED-based lighting is gaining popularity in automotive applications with both LED makers and LED light engine designers in need of more robust, efficient solutions that enable OEMs to realize the full benefits of energy-efficient LEDs,” noted Doyle Slack, senior marketing director for Analog. “By integrating the core functions critical to automotive LED lighting, the MAQ3203 driver IC offers a compact all-in-one solution that requires few additional components, enabling more cost-effective, elegant and reliable LED module designs.”

Micrel

www.micrel.com

Six-channel analog front end

targets 3-Phase measurement

Microchip Technology has announced its first high-accuracy, stand-alone six-channel analog front end (AFE) for three-phase energy metering. The MCP3903 AFE includes six 16-/24-bit Delta-Sigma analog-to-digital converters (ADCs)

and offers a signal-to-noise and distortion (SINAD) of 89 dB (typical) and total harmonic distortion (THD) of -99 dB (typical). Additional integrated features include programmable gain amplifiers (PGAs), a low-drift voltage reference and phase-delay compensation, for a reduced external component count that increases design flexibility and lowers costs. The MCP3903 AFE targets the utility and industrial

markets, such as utility meters, power-monitoring devices and instrumentation devices. Trends in smart metering have dramatically increased the need for products that offer precise measurements in multi-phase metering, while simplifying designs and reducing costs.

The MCP3903 claims to deliver this functionality by providing a highly accurate solution with integrated features that enable design flexibility. The MCP3903's six 16-/24-bit Delta-Sigma ADCs enable the simultaneous sampling of six inputs, making it suitable for three-phase power monitoring and metering.

Microchip Technology

www.microchip.com



HDMI signal-conditioning IC

offers transmission line ESD protection for HDMI

NXP Semiconductors' IP4786-CZ32 is a highly integrated HDMI signal-conditioning IC claimed to provide the industry's highest levels of protection for HDMI 1.4 transmitter applications. Featuring a Transmission Line Clamping architecture that provides lower peak

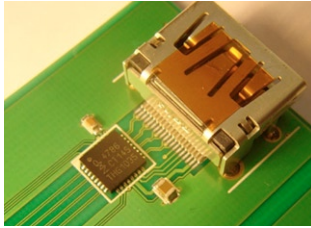

clamping voltages during an ESD strike, the IP4786 delivers strong ESD protection, excellent signal integrity and a high level of integration. Designed for home entertainment systems, such as set-top boxes, standard-definition (SD) and high-definition (HD) DVD players, Blu-ray players and A/V switches, the IP4786 also features low power consumption in standby mode.

"Zero-clamping" buffers on the control lines completely isolate the HDMI signals from an ESD strike. All 13 signal lines are rated for ± 8 kV in accordance with

the IEC 61000-4-2, level 4 standard, as well as the 5V power source pin. In addition, the IP4786CZ32 incorporate an overcurrent limiting 5V LDO, conforming to the HDMI 1.4 requirement for overcurrent protection. The TLC protection architecture integrates impedance-matching inductors along with the ESD protection device, providing matched 100 ohm differential impedance through the device.

NXP Semiconductors

www.nxp.com

Resistive touchscreen controller

detects both proximity and pressure

Semtech's SX8654 / 55 / 56 / 57 / 58 ultra low power 4/5-wire resistive touchscreen controllers integrate proximity sensing and haptics control for driving motors. These feature-rich controllers also come with on-chip ± 15 kV ESD protection making them ideal solutions for a wide variety of handheld applications. This resistive touchscreen controller platform supports a proximity detection distance of more than 5 cm using any standard 4/5-wire resistive panel, en-



abling various power-saving features such as automatic backlight activation or system wake-up. Unlike traditional IR solutions that require additional, costly components for proximity detection, these controllers do not require additional components. The SX8654/55/56/57/58 feature

an accurate 12-bit analog-to-digital converter for coordinates and touch pressure measurement with current consumption as little as 30 μ A at 8kSPS rate.

The SX8654 family enters a low power state between conversions to save power consumption. The devices also incorporate a haptics motor driver for controlling Linear Resonant Actuator (LRA) and Eccentric Rotating Mass (ERM) micro motors (up to 250 mA) while providing acknowledgement to touch events, thus

emulating the tactile feedback similar to mechanical keys which enhances the overall user experience. The haptics waveform can be input via the I²C interface or with an external PWM signal.

Semtech

www.semtech.com

Analog



EETimes Europe Analog is the design, news, and product resource for engineers involved in the design or implementation of analog, power, sensor, data converter, signal processing, and RF ICs and components.

The target audience includes both the engineers and the project managers involved in the design of analog circuits, systems, interfaces, and functions. Its mission is to serve both the analog designer, as well as the digital designer involved with analog system attributes, with technical information that will improve, ease, and speed the design process.

<http://www.analog-eetimes.com>

EETimes
europe
ANALOG

Record and replay in global navigation satellite system testing

By Julian Thomas

CUSTOMERS AT VEHICLE manufacturers and proving grounds need tests such as brake distance measurement to be accurate to 2cm. Before 2008 there were two options: live sky testing and simulation. Racelogic has always used live testing, which involves taking equipment out in vehicles on the road and around test tracks. This is useful for getting real world data, but the changing nature of satellite constellations means that no test can ever be repeated. The company's development team also found constant testing in the field to be time and labour intensive.

Therefore, for some tests we used an expensive artificial GPS simulator, which modelled the satellite signals modified with a user generated trajectory. However, the test engineers found that this didn't sufficiently reproduce the real world environment. The results were not always a good indication of how their GPS products would actually perform in the real world. Neither live sky field testing nor GPS simulation was adequate. The dynamic nature of satellite constellations meant field tests were time intensive and not repeatable, whilst modelling satellite signals was expensive and couldn't reproduce actual conditions.

Developing record and replay technology

So we began to research a system that would have the ability to record live GPS signals and then replay these into products under test. The brief was that it would offer realistic data, in the same way as live sky, but that it would also be consistent, with the ability to repeat a test, or 'scenario', as many times as necessary. It would also need to be affordable.

With nothing else available, Racelogic decided to design something that could record live global navigation satellite system (GNSS) signals and replay these into devices

under test, offering the blend of realism and repeatability that they needed at an affordable price. In 2008, we developed LabSat – see figure 1 - which had the ability to record raw GPS RF signals from a live antenna to be replayed at a later date. Users could now easily record a journey and replay this on the bench with identical results. With this module, Racelogic found it could reproduce the data from a real brake test activated using a switch on the brake pedal, to within 2cm of the physically measured distance (verified by a laser) all from the test bench. Soon five units were in constant use, and from the feedback of our R&D engineers it was clear that LabSat could be helpful to other companies developing GNSS products.

Software simulation

Some testing scenarios are inherently difficult to record, such as a complex route in distant country, a test crossing meridian lines or a time based test involving a GPS year rollover. For these situations, Racelogic developed the SatGen scenario generation software. SatGen allows the user to define a custom route, anywhere in the world, at a predefined time and date. There is even a Google Earth import feature which makes the definition of the profile very simple. This profile information is then converted into a scenario file which can be replayed on LabSat devices. The additional advantage of an artificially created test is the quality of the simulated data; for example, if you need to precisely control the speed, heading, position or height, then this is very simple to do and the output from LabSat will be extremely precise.



Fig. 1: The LabSat unit

LabSat is now used in several industries. For example, Nokia and Blackberry use LabSat for testing smartphones; Mercedes Benz, Bosch and Continental use it to test in-car navigation systems; BAE systems use LabSat to test the latest defence technology; and Road Angel use it to verify that their GPS safety camera and black spot locators are operating correctly.

Six thousand hours of testing

For Road Angel it's vital that the products work 100% of the time, or the company would risk complaints from customers who claim that their device failed to warn them of speed cameras. Previously, Road Angel's technicians had to individually test units by driving past known speed camera locations

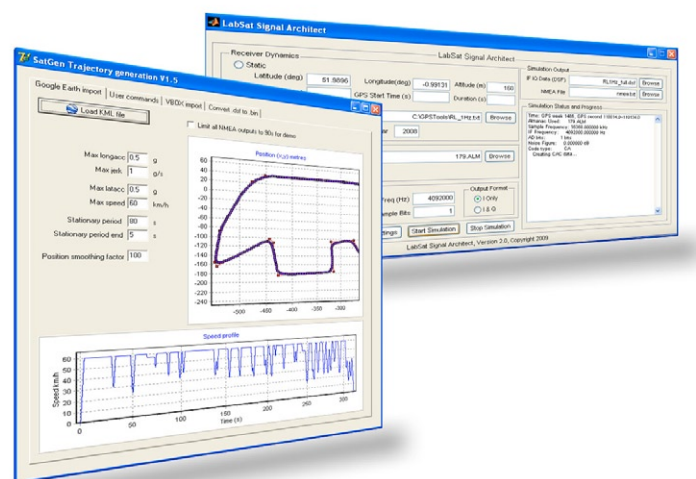

Fig. 2: SatGen artificial Scenario creation software.

Julian Thomas is Managing Director of Racelogic – www.racelogic.co.uk - he can be reached at julian.thomas@racelogic.co.uk

and identifying the units which failed to activate, indicating a malfunction in the GPS system. Because this method required a vehicle and driver, it was time consuming, expensive, and only provided subjective reporting of errors. Having heard about record and replay technology, Richard Meechan, Road Angel's Development Director, went out with a LabSat and recorded a live route incorporating several speed camera types and locations, for later replay into units under test.

"We had LabSat running 24/7 in our lab for over two weeks, replaying a thirty minute test drive into twenty test units at a time." Meechan continued: "Each block of units had a different version of firmware installed. LabSat was used to evaluate how well each version detected the various speed camera systems recorded, including new types of cameras introduced since the original firmware was released. In two weeks the LabSat record and replay system saved us over six thousand hours of testing of our new Vantage GPRS connected speed camera locator."

Road Angel is also a user of Racelogic's simulation software, SatGen. By creating scenarios in the SatGen software to create realistic data in which to playback through units under test, engineers can test the operation of their devices anywhere in the world. They have found it useful in instances where customers claim that their product failed to indicate a camera, or where the device indicated a camera where there was none. Testing engineers can use SatGen in conjunction with Google Earth to recreate a test drive past the area where the device was claimed to malfunction, to see what went wrong and repair it.

Extended simulation

Sometimes just simulating the GPS signal is not enough, as there may be other sensors involved in the successful operation of the system under test. Not only that, but actual motion may be required to stimulate embedded gyro sensors in order for the system to operate in a realistic fashion. For example, it is very common for a built-in Satellite Navigation system to use gyro and wheel speed information to supplement the GPS signal for poor satellite visibility areas such as urban canyons and tunnels. The gyro signal and wheel-speed data are often available on the CAN bus of the vehicle, which is an efficient way of connecting sensors around the

vehicle, but makes simulation more difficult.

In order to accommodate for this kind of test scenario, LabSat has various input and output capabilities which are flexible enough to cover a number of different configurations. On the input side, there is a high speed digital input which is sampled on every GPS sample, providing a tightly synchronised record of the digital data. The recorded digital data is then reproduced on the output port at the same time as the GPS RF data is replayed. In order to convert real world signals into a digital format which can be recorded by LabSat, there are a number of different conversion modules available such as RS232, RS422, RS485 and CAN.

In some cases, the gyro sensor may be built into the main navigation unit, which makes it very difficult to record and replace the data from this sensor. In these cases, physically rotating the unit can be the only option. In order to overcome this difficulty, LabSat has a built-in GPS engine, which is used to monitor the output during the replaying of GPS data.

The data from this GPS engine can be transmitted on a USB or serial link, and configured to control a precision turntable to reproduce the heading measurement corresponding to the direction in which the GPS antenna would be travelling.

In operation this is very effective, as the



Fig. 3: A setup on a precision turntable can reproduce GPS heading to test the unit's gyro response.

device under test is turned through exactly the same angle as it would have been in the real world. This means you can use pre-recorded scenarios, or artificially generated scenarios, the results are the same, and the device under test receives realistic signals from the internal gyro.

Nothing beats testing in a real world scenario, however, the ability to reproduce over and over again exactly what happened on the test drive, is invaluable in the development and testing of integrated GPS based systems. An engineer can build up a library of useful test drives, and mix this with a number of artificial scenarios which are normally difficult to achieve in real world testing, such as crossing meridian lines and year rollover tests. From then onwards, most of the functional testing can be carried out on the bench with a high level of repeatability, in a very controlled environment.

Synchronizing with video

One of the disadvantages of testing with real world data on the bench is that you cannot see the exact conditions which were experienced by the receiver when the data was recorded. You may have satellite drop-outs or multipath caused by tall buildings, bridges or even passing traffic, but when it is replayed on the bench, it would be difficult to know why this was happening.

To overcome this situation, Racelogic can supply a synchronized video system which is fitted to the car at the same time, which records video alongside the GPS RF data. When the data is replayed on the bench back at the office, the video plays alongside, fully synchronized at all times, allowing you to observe the exact conditions which were present during the original recording. ■



Fig. 4: A typical vehicle CAN connection.

Data logging without gaps

By Jochen Neuffer

IN ORDER TO simulate real situations for the communication networks in a vehicle it is necessary to perform extensive test drives in a real environment. Large amounts of data need to be acquired, recorded and, afterwards, accessed. Here is how this can be achieved.

In vehicles often different bus systems are used which significantly increases the effort for troubleshooting and analysis. In order to simulate real situations for the communication networks in a vehicle it is no longer sufficient to perform tests in the laboratory only. Therefore it is necessary to perform extensive test drives in a real environment. The test fleet is typically equipped with dedicated data loggers, the tool of choice for recording data traffic of all busses as well as selected I/O lines. So this data can be accessed at any time during quality assurance tasks. Shortly before production maturity, in-depth testing in vehicles is typically conducted in the context of test drives. To achieve the greatest possible test coverage, some of these tests are performed under extreme environmental conditions. Whether they are winter tests in Finland at -30° C, hot weather tests in Death Valley at over 50° C or week-long drives through the Brazilian rainforest at high humidity and on rough roads, in the end the vehicle and all of its components must operate smoothly. The installed data loggers must be able to withstand these harsh conditions as well. This means that they must be mechanically rugged and operate reliably over a broad range of temperatures.

Various bus systems are used in motor vehicles or commercial vehicles: CAN, LIN and FlexRay. One technical requirement is that the data of all of these buses needs to be logged simultaneously, i.e. time synchronously. The logger must not influence the bus traffic here; it may only observe it. Since the loggers are often permanently installed in test fleet vehicles, and a test series may take several weeks, they must exhibit very

low current draw in their quiescent states – another requirement of data loggers. Furthermore, the devices must be ready for operation as quickly as possible, so that the first occurring message can be logged too.

Not only are the loggers typically permanently installed. Often they are mounted at very inaccessible points, e.g. under a seat or behind a trim panel in the cargo space, and they may be inaccessible because of other instrumentation. Therefore, it is advantageous if the test engineer can use a UMTS or WiFi wireless connection to read out data from a logger. As an alternative, it should also be possible to read out data directly via USB or by swapping out the memory medium. To permit clear traceability of certain driving situations to a specific error pattern in later offline analysis and troubleshooting, the test driver has the option of recording audio comments and camera images along with the regular data during the test drive. In parallel, GPS data can be added to the bus communication for geographic reference. After logging, the data is typically converted on the PC, so that it can be analyzed in other programs such as CANoe, CANalyzer or CANape.

Test fleets need special data loggers

At first glance, it would seem reasonable to use a notebook-based solution for in-vehicle logging. Together with a suitable net-

work interface the notebook should be able to offer all required capabilities, since functionality can be implemented in software. However, commercially available notebooks cannot handle the required temperature range. Furthermore, the system must first be booted, which takes some time – even with fast notebooks. This implies another requirement for data loggers: short startup times. Data must be acquired quickly enough for the first message on the bus to be logged. All of the noted requirements are fulfilled by special fleet loggers such as devices of Vector's GL3000/GL4000 logger product line – see figure 1. Their extended temperature range also makes it possible to use them under extreme environmental conditions.



Figure 1: Special data loggers for in-vehicle use need a rugged, robust design.



Figure 2: For data loggers, a broad choice of interfaces is mandatory.

Jochen Neuffer is Product Management Engineer at Vector Informatik - www.vector.com

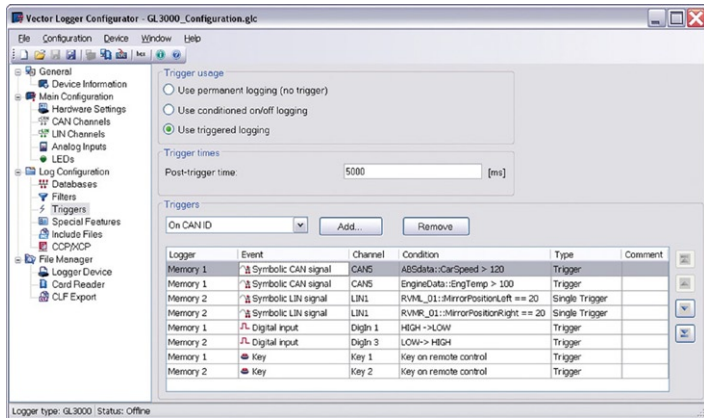

Figure 3: Trigger configuration in the Vector logger configurator.

These special fleet loggers also have a real-time clock, ensuring clear time references for the acquired data.

Processing the data

To reduce the volume of incoming data, even during the test drive, these loggers let users start logging only in response to pre-defined events. In triggered logging, data is continually written to a ring buffer. When the trigger event occurs, this ring buffer is closed, and the data is saved.

Logging is then resumed in a new ring memory. This method substantially reduces data volumes compared to continual logging. Depending on the configuration of the ring buffer, logged data may be available for a time period before the trigger and possibly for a configurable post-trigger time after the trigger occurs. The ring buffer is usually configured with special software – see figure 2. The special script language Logger Task Language (LTL) can be used to execute complex logging tasks. This can be illustrated by a simple programming example: Creating a classing table during logging. First, the symbolic signals Speed and Brake from a database are automatically converted to LTL code. The test engineer only needs to add supplemental code for classing with the CLASSIFY operator:

```
VAR Speed = CANr DATA 20oh [2 3]
    Brake = CANr DATA 10oh [3(0)]
CLASSIFY
    MyClassify COUNT (Brake)
    OVER Speed (20 CLASSES OF 10 BASE 0)
```

In this example, the Variable Speed value is defined in km/h over 20 classes, each class has a width of 10 km/h, and 0 km/h is set as the start value of the first class. The data of each classing task is saved in text-based results tables that can easily be read into a program such as MS Excel for post-editing.

Currently, there are many different data loggers on the market. However, only fleet loggers are suitable for the harsh operating conditions in the automotive field. Loggers should offer a wide range of features that covers the majority of requirements for today's vehicles during test drives. They include a large number of CAN, LIN and FlexRay channels, short start-up times and I/O ports on the logger. UMTS, WLAN, USB and Ethernet offer the necessary flexibility to configure the loggers and transfer the logged data. Fleet data loggers from Vector, with their extended temperature range and durable packaging, equip the test engineer with devices ideally suited for use under extreme environmental conditions. ■

Automotive Electronics



EETimes Europe Automotive Design Centre is the premier European design resource for engineers and engineering managers involved in the development of automotive systems and equipment. The site provides engineers and engineering managers with detailed technical information that will improve and ease design of power train systems, chassis and suspension systems, automotive safety and security systems, body electronics, and automotive infotainment systems.

<http://www.automotive-eetimes.com>

EETimes
europe
AUTOMOTIVE

Achieving Gen2 Serial RapidIO throughput with low cost, low power FPGAs

By Ron Warner

AS BANDWIDTH REQUIREMENTS for applications such as wireless, wireline and medical/imaging processing continue to expand, designers depend on tool sets that provide them with the real-time signal processing capabilities that are needed. For example, in the wireless world, with existing 3G overlays and emerging 4G deployments, the emphasis is on data throughput and backhaul requirements that can support a rapidly increasing subscriber base and the enor-

endpoints. For those not familiar with SRIO, figure 1 illustrates the RapidIO protocol stack. RapidIO is a three layer specification divided into a Physical (PHY) Layer protocol, packet transport (routing) protocol and multiple transfer types at the Logical Layer. This article will examine the Serial portion of the PHY layer, since the Transport and logical layers in v1.3 and Gen2 Serial RapidIO are fundamentally the same.

tion would be excessive. This is where the 2x SERDES lane configuration can now provide an effective solution that allows designers the option to stay with a low cost, low power FPGA solution, such as the LatticeECP3, which supports most applications offering link configurations of 1x, 2x and 4x lane configurations at speeds up to 3.125Gbps. Where the customization and flexibility of an FPGA comes into play is at the logical layer, where multiple traffic passing techniques can be implemented. As shown in figure 1, there are four various data passing protocols. These are direct I/O access, message passing, data streaming and GSM. The logical layer can be customized, depending on the system architecture/requirements, to define how SRIO endpoints exchange data. For the purposes of this article, we will focus on I/O System transactions with varying packet sizes and their associated overhead, and the impact on overall throughput calculations.

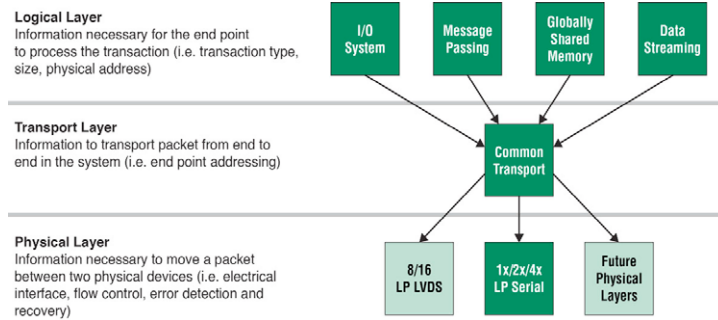

Fig. 1: RapidIO protocol stack

mous amount of video and data applications enabled by smartphones and other handheld devices. Reliable, high speed processing is needed to enable the high throughput, low latency interface protocol that can support the various DSP farms, co-processing and bridging applications that are necessary. And, as with most systems, cost and power are of the utmost importance, as well as the flexibility of a programmable platform to allow for customization. DSP and Network Processing Unit (NPU) devices, coupled with low cost, low power FPGAs that support SerialRapidIO (SRIO) Gen2, can provide an ideal platform for meeting these challenges.

SRIO - Protocol overview and lane configurations

The RapidIO specification is a packet-based technology defined for endpoints, which originate and process packets, and for switches, which are used to connect

When considering low cost, low power SERDES-based FPGAs, data rates are typically maximized at 3.125Gbps per lane. Therefore, the most important enhancement in the GEN2 specification is the 2x lane configuration, because in many cases systems need more throughput than a single 3.125Gbps lane can provide, but a 4x lane configura-

tion would be excessive. This is where the 2x SERDES lane configuration can now provide an effective solution that allows designers the option to stay with a low cost, low power FPGA solution, such as the LatticeECP3, which supports most applications offering link configurations of 1x, 2x and 4x lane configurations at speeds up to 3.125Gbps. Where the customization and flexibility of an FPGA comes into play is at the logical layer, where multiple traffic passing techniques can be implemented. As shown in figure 1, there are four various data passing protocols. These are direct I/O access, message passing, data streaming and GSM. The logical layer can be customized, depending on the system architecture/requirements, to define how SRIO endpoints exchange data. For the purposes of this article, we will focus on I/O System transactions with varying packet sizes and their associated overhead, and the impact on overall throughput calculations.

At a high level, the key additions to the Gen2 specification are support for 5/6Gbps serial data rates (SERDES) and the addition of a 2x lane configuration for these high speed serial channels (versus just a 1x/4x available in the previous v1.3 ver-

SRIO - Transaction types/sizes

Various transaction types and associated packet sizes were tested by Lattice to understand and report the overall throughput achievable. The transactions chosen were the most common type of transfers that

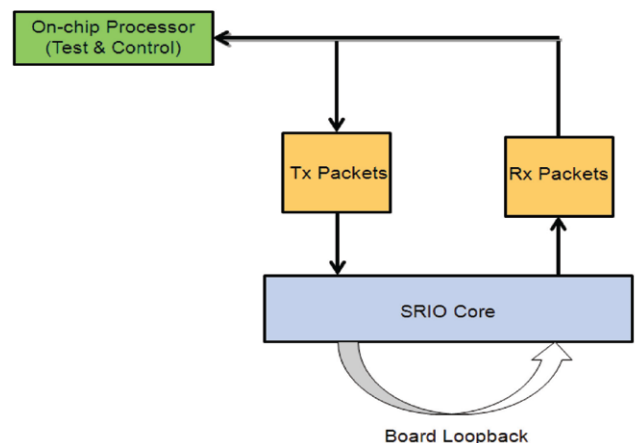

Fig. 2: Throughput test environment

Ron Warner is a strategic marketing manager at Lattice Semiconductor - www.latticesemi.com

be pipelined such that reply and sending overhead do not compete with each other for bandwidth. This is different from many traditional busses, which require turnaround cycles and arbitration phases that add to the overhead. Now that we have examined the types of transactions used and the basic nature of packet overhead, let's take a look at the various packets that are transported and the throughput achieved as a result of each. Figures 5 and 6 below show the high-level structure of both NWRITE and SWRITE packets. The grey shaded areas represent the overhead bytes in each transaction type. The payloads for both were tested at various byte values, which are reflected in the final throughput diagram. Therefore, with NWRITE throughput at a payload size of 256 bytes, the theoretical maximum efficiency would be $256 / (256 + 22) = \sim 92\%$.

Similarly, as shown in Figure 6, with SWRITE throughput at a payload size of 256 bytes, the theoretical maximum efficiency would be $256 / (256 + 20) = \sim 93\%$. Taking into consideration link maintenance at $\sim 1\%$ and the SRIO core overhead of $\sim 5\%$ (due to Logical Layer port priority, Tx arbitration and queuing), the theoretical is reduced to a real world value of $\sim 86\%$. Various packet sizes were sent and, when comparing actual measured results, it was not surprising that the larger the packet size, the better the throughput. Figure 7 shows the combinations of lane widths and packet sizes tested and the resulting throughput. As an example, the theoretical limit of a 1×3.125 Gbps configuration at 256 bytes would yield a throughput of 312.5 MB/s. However, the throughput measured in this configuration was 269 MB/s, or about 86% of the calculated theoretical limit, which matches the real world value calculated above.

We have now explored some of the throughput capabilities achievable utilizing a mid-range programmable platform to implement an SRIO endpoint. Low cost, mid-range FPGAs have historically played various roles in system designs, but are now pushing the performance envelope, as evidenced by 4×3.125 Gbps capabilities, that make attractive design choices for key roles such as signal path applications. Since system designers will remain under continual pressure to produce more for less, these FPGA devices can enable them to achieve balance in the ongoing battle of system performance versus build and operational costs. ■

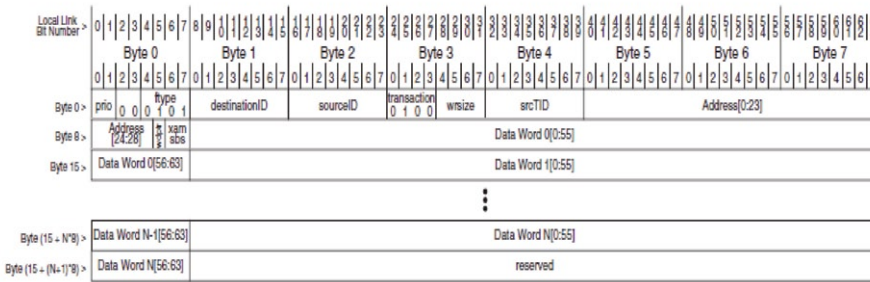

Fig. 3: NWRITE packet

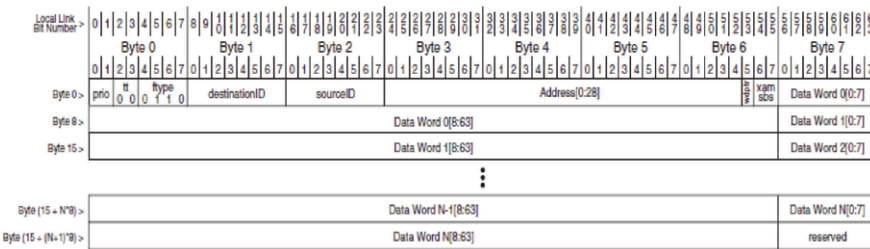

Fig. 4: SWRITE packet



Fig. 5: NWRITE packet

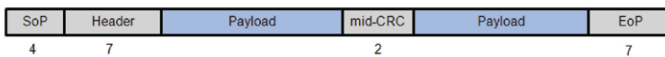

Fig. 6: SWRITE packet

would likely dominate typical applications. Figure 2 represents the test logic that was utilized for this scenario.

For the purposes of throughput testing, Lattice chose to use NWRITE and SWRITE transactions, as these are the more common types of transactions used to handle the

transport of larger blocks of data. In this scenario, data transaction was governed by an onchip processor that loaded the Tx packets, initiated the transactions and then monitored the Rx side to determine the number of packets sent/received. Figures 3 and 4 below show the structure of these packet types.

One performance concern for any system is obviously the transaction overhead. RapidIO is a full duplex interface that can

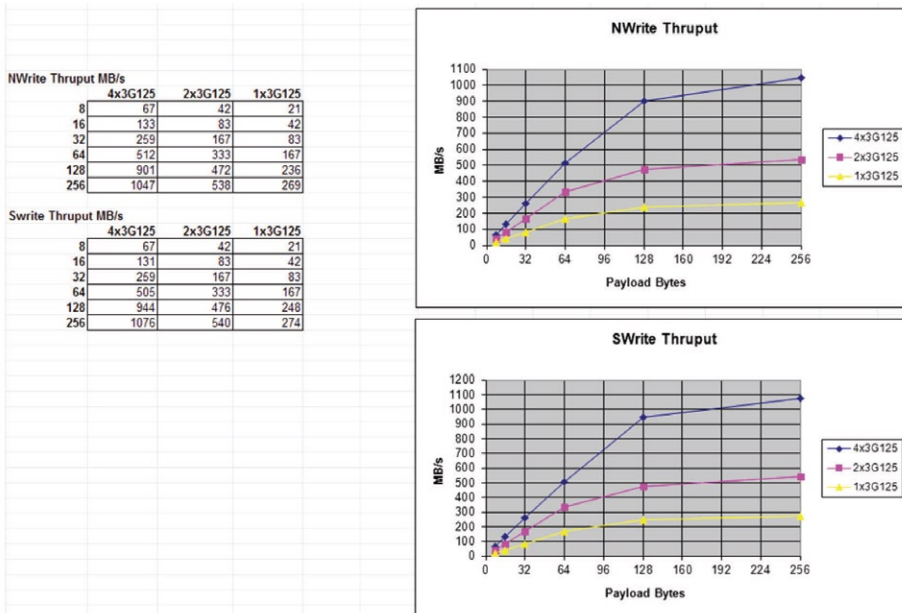

Fig. 7: Throughput summary

PXI RF vector signal analyzer

extends test performance to 14 GHz

National Instruments has introduced a 14 GHz version of its PXIe-5665 high-performance RF vector signal analyzer (VSA). Because of its PXI platform, the VSA can deliver measurement speeds up to 20 times faster than box instruments and for less cost. Additionally, it takes advantage of multicore computing architectures and parallel programming capabilities through LabVIEW system design software. It also offers peer-to-peer data streaming for signal processing and a flexible multiple input, multiple output (MIMO) architecture for phase-coherent measurements. Such features make it suitable for demanding RF test applications including radio detection and ranging (RADAR), satellite, radio and harmonic testing.



The VSA offers the same industry-leading performance as the 3.6 GHz version of the PXIe-5665 while extending the capabilities into the 14 GHz frequency range. The VSA consists of the latest

PXIe-5605 downconverter, the PXIe-5653 local oscillator synthesiser and the PXIe-5622, a 150 MS/s intermediate frequency (IF) digitiser.

It features the industry's best third-order intercept point at +24 dBm with an absolute amplitude accuracy of ± 0.10 dB as well as an error vector magnitude of 0.33% for a 256 QAM modulated signal. It also delivers a low phase noise of -129 dBc/Hz at a 10 kHz offset at 800 MHz and an average noise level of -165 dBm/Hz.

National Instruments

www.ni.com

Digital direction finding receiver

offers 120MHz instantaneous bandwidth

The dual channel digital wideband receiver IZT R4000-DF2 covers a frequency range from 20MHz up to 6GHz with an impressive 120MHz instantaneous bandwidth. The R4000-DF2 features a flexible

real-time fast Fourier transform (FFT) processor to save valuable computing time in the customer's direction finding (DF) processing software and to shorten the time needed for scans and signal detection. Based on the hardware of the new IZT R4000 digital receiver and signal collection system, the wideband DF receiver features an additional fast, frame-synchronous antenna switch and

a calibration source. The unit offers two 1Gbit Ethernet output interfaces per receive channel and for customers who look for more than 2Gbit output, a 10Gbit option is available.

The IZT R4000-DF2 uses FPGA based signal processing to deliver FFT spectra via LAN to the custom-

er's DF processing software. The FFT length of 32,768 provides 5kHz frequency resolution at maximum bandwidth. The devices' gain can be controlled automatically (AGC) or manually in 2dB-steps.

IZT

www.izt-labs.de



33GHz oscilloscopes

offer real time sampling rates up to 100GS/s

The four new DPO/ DSA70000D Series oscilloscope models offer real time sampling rates up to 100 GS/s on two channels and 33GHz analog bandwidth on four channels. Using IBM's 8HP silicon germanium (SiGe) chipset, Tektronix has integrated high-speed bipolar transistors on the same die as standard CMOS, giving faster rise times on multiple channels. Tektronix claims this delivers the fastest rise times of any real-time oscilloscope on the market, as required for accurate characterisation of high speed optical, RF and serial data measurements beyond 20 Gb/s data rates. With fiber speeds now at 100 Gb/s and beyond, engineers are trying to accurately verify Optical Modulation techniques for efficient

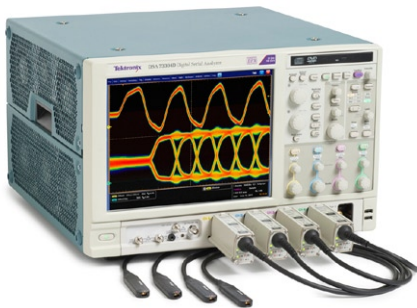

fiber transport.

The DPO/DSA70000D provides the 4-channel accuracy required for PM-QPSK modulation analysis. The 70000D Series works with Optametra's (a Tektronix technology partner) Coherent Lightwave Signal Analyzer for visualization and measurement of optical PM-QPSK or QAM16 and other complex-modulated signals.

Tektronix

www.tek.com

26.5 GHz and 43 GHz signal analyzers

for measurements in the microwave bands

Anritsu released the 26.5 GHz and 43 GHz models from its series of MS2830A vector signal analyzers. The two latest models now meet the need for measurements in the microwave bands, either using the spectrum analyzer's standard function or with the optional function of

the signal analyzer as well as having all the available power of the built-in FFT tool. Models MS2830A-044 and -045 also replace the previous MS2667C and MS2668C platforms while offering much better radio performance and measurement speed than the previous generation. For higher frequency applications (beyond 43 GHz), the standard MS2830A-044/045 model allows combination

with external mixers to support frequencies up to 110 GHz or even 325 GHz, depending on the manufacturer specifications. As the MS2830A has a very high intermediate frequency (1.875

GHz), this enables the spectrum analyzer to operate with a reduced number of harmonics beyond 43 GHz, therefore

ensuring a better dynamic range measurement is available. In addition, complex signals with very wide bands (up to 1 GHz) can be processed by the spectrum analyzer or the FFT analyzer and can even be observed on a wideband oscilloscope using the MS2830A IF output port with no signal deterioration.

Anritsu

www.anritsu.com



10 MHz USB data acquisition module

with two isolated analog inputs

With its DT9862 data acquisition module, Data Translation wants to set new standards in 16-bit high-speed data acquisition via USB 2.0. All I/O channels are galvanically isolated to ensure ultra-high measurement accuracy and signal integrity. In addition, the new module also features flexible clock and trigger functions (e.g. pre-, post- and about-trigger modes). Unlike conventional data acquisition modules, the DT9862 does not multiplex the input signals, but provides a separate A/D converter for each input



channel. In burst sampling mode, the new module achieves a maximum sampling rate of 10 MHz for each of the two channels. In streaming mode, it can sample either one channel at 10 MHz or two channels at 5 MHz each, and transfer the data directly to the PC.

Data Translation

www.datatranslation.eu

Analog and digital radio test set

USB-connected for easy programming

Aeroflex released the 390XOPT604 automatic test and alignment software option for Motorola's APX 7000 and 7500 mobile radios. The APX Series radios are dual band and can be configured with any two band combinations. The application will test and align both bands. Mobile power alignment is included in this option and alignment time for both bands on the APX mobile is approximately 16 minutes. The radio's standard USB programming cable is used directly by the 3920 to control the radio in test mode. Both analog and digital tests are performed to ensure the radio is performing at optimum performance. Alignments are available for power, frequency, deviation balance and front End. P25 Performance tests are available for modulation



fidelity, symbol deviation and RX BER (Bit Error Rate). Proper alignment will ensure the radio has maximum coverage performance. Test results are automatically stored each time a radio is tested. Stored test results can be moved to a computer or printed directly from the instrument itself. Specifications are user definable and the application also has the ability to sweep test cables to gain a loss factor for each test frequency that is being tested. Loss factors can be much different between frequencies and bands. The compensation factor is automatically applied to all power readings as well as a compensation factor for the signal generator when testing RX BER.

Aeroflex

www.aeroflex.com

5 GS/s digitizer

in a portable USB format

The PicoScope 6407 USB Digitizer provides high-speed data capture for almost any industrial or scientific application. With four 1 GHz 50-ohm analog inputs and a 5 GS/s sampling rate, the instrument can handle a wide variety of signals such as high-speed serial data; waveforms from automated test rigs, prototype circuits and high-frequency PCBs; radio, laser and radar IF signals; and many types of experimental data. The 1-gigasample memory buffer on the PicoScope 6407 allows high-speed capture of very long data records. A USB stream-



ing mode allows continuous capture of unlimited amounts of data at up to 13 MS/s.

Unlike systems such as PCI and PXI that require a specialized backplane or mainframe, the USB-connected PicoScope 6407 is a compact, low-cost instrument that can be plugged into any Windows PC or laptop.

PicoScope

www.picotech.com



productronica 2011

19th international trade fair
for innovative electronics
production

Register online and enjoy the benefits:
www.productronica.com/benefits

november 15-18, 2011
new munich trade fair centre
www.productronica.com

innovation all along the line

A19 LED bulbs: What's under the frosting?

By Martine Simard-Normandin

STANDARD A19 FORMAT light bulbs, found today in most lamps and luminaires, are now available in LED versions that retail between \$20 and \$40 per 40W- or 60-W-equivalent bulb. Some bulbs are dimmable, some not, and some only with specific dimmers. They all advertise 25,000 to 50,000 hours' expected lifetime, based on three to four hours' daily usage. If you use them appropriately and sparingly, you might expect your light bulbs to outlive you.

But why are the bulbs so expensive? Do they provide real value for the price? And why are some bulbs twice the price of the others?

In our scientific quest for answers, MuAnalysis Inc. tore apart five A19 LED bulbs: a Philips 60-W equivalent, at 12.5 W and 800 lumens, and 40-w equivalents from Feit, GE, Pharox and Sylvania. Our examinations of the five bulbs raised still more questions. (For the full report, go to www.muanalysis.com.)

Each of the bulbs comes in a specially designed package, unlike tungsten filament and CFL bulbs, which ship in nondescript shrink wrap. The fancy packaging adds to the overall cost.

These bulbs clearly are not yet positioned as commodity items; they are expensive and are expected to last. But the price of electronic gadgets has dropped so much of late that longevity is no longer the main concern. So why is a common light bulb more expensive to buy than a cheap digital camera?

Looks count in a category as simple as light bulbs, and each of the bulbs we examined has a unique appearance. For example, the GE bulb has a ceramic neck and fins and a glass bulb, and is more costly than those using plastic and metal.

All of the bulbs have a small printed-circuit board contained within the neck, relying heavily on large electrolytic capacitors and transformers. The reliability factor of

Martine Simard-Normandin is president and CEO of MuAnalysis Inc. (Ottawa), a privately owned professional laboratory.

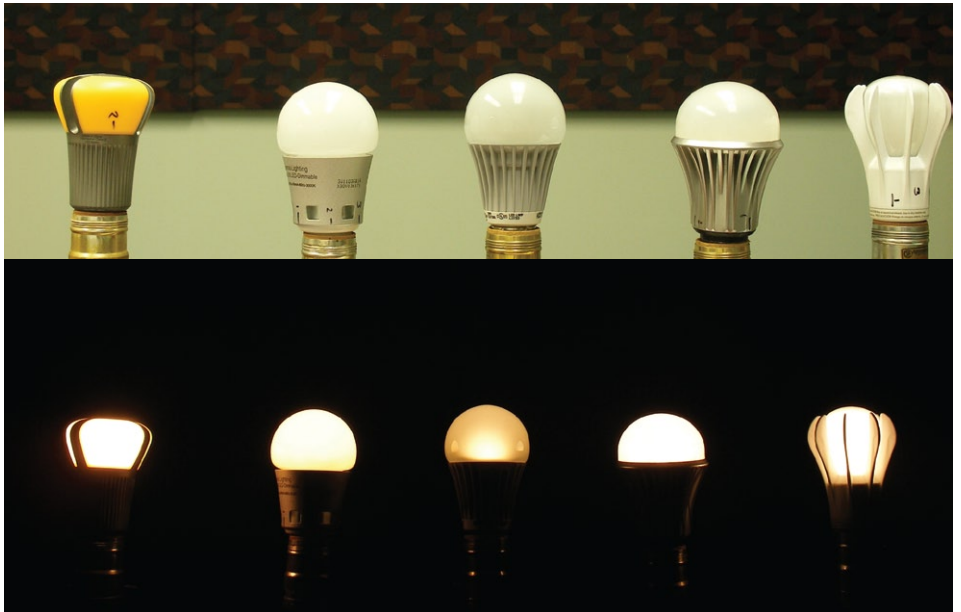

LEDs has increased tremendously. But how long will electrolytic capacitors perform under such hot operating conditions?

The dimmable bulbs incorporate silicon-based Infineon or ST power transistors. We did not find silicon carbide technology in any of the lamps.

Each lamp uses a different LED driver

IC. Pharox uses four ICs, 40 resistors and 16 capacitors, plus transformers and many diodes. All this to dim a 40W-equivalent light bulb—but only, in some cases, if you purchase a new dimmer, since your old dimmer might not be compatible.

Philips uses a remote phosphor, relying on the bulb envelope material to do

	Sylvania Ultra High Performance Series LED	Philips AmbientLED (household usage)	GE Energy Smart	Feit Performance LED	Pharox 300
Energy used (W)	8	12.5	9		
Life (hours)	50,000	25,000	25,000	25,000	35,000
Light output (lumens)	430	800	450	450	360
Efficacy (lumens/W)	54	64	50	60	60
Light color	Bright white	Soft white	N/A	Soft white	Warm white
Correlated color temperature (K)	3,000	N/A	3,000	3,000	2,900
Dimmer compatibility	Yes	Yes	No	No	Certain models only
Purchase price (\$)	39.99	39.98	42.89	21.98	24.95

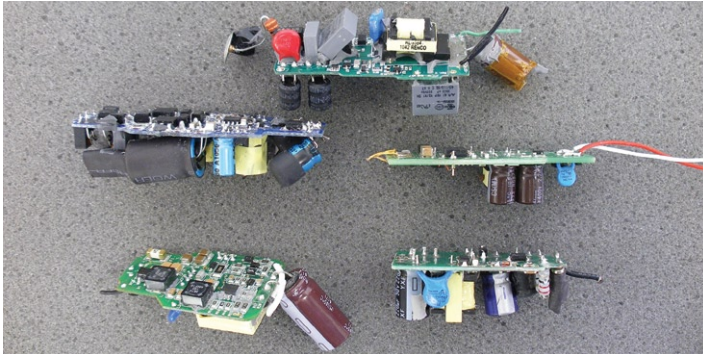

All of the bulbs have a small pc board within the neck, relying heavily on large electrolytic capacitors and transformers.

the wavelength conversion. Lutetium oxide is used as a fluorescent medium in more than one lamp. We have looked at many LEDs over the last few years and have never seen lutetium used before. More conventional phosphors, such as barium and cerium-doped YAG (yttrium aluminum garnet), are also seen, along with a cocktail of rare earths such as europium and strontium.

Surprisingly, everyone uses blue GaN LEDs—no RGB LEDs in this lot. There are red LEDs in the Pharos, complete with lenses, but they don't turn on when the lamp is on. They are obviously not for color balance. Maybe the light turns red when the bulb is about to die, or to signal that the lamp is not wired properly.

Philips uses many of its own Luxeon Rebel LEDs in a modular arrangement that could possibly permit the replacement of failed modules. We expected the Sylvania to use an Osram LED, perhaps a Dragon, but that is not the case. Two of the lamps rely on Cree dice.

The LED light-emitting area varies from 4 mm² to 12 mm² for the 40-W equivalent bulbs—a variance of a factor of 3—yet their power consumption ranges between 6 and 9 W. Some have four LED dice; others have 48. At what point is such a lamp considered to have reached the end of its operable life, given its dozens of individual LEDs? Nowhere on the fancy packaging, with all its warnings, disclaimers and warranties, is there a definition of the point of final failure for the lamp. Will it go out with a flash? Will it still be usable for its intended purpose until the last second, or will there be a point at which the light has become so faint that the user decides to replace the bulb?

Lots of questions, and we still haven't answered the first one: Why are A19 LED bulbs so expensive? At 50 to 60 lumens/W, the LED bulbs have the same efficacy as 40-W-equivalent compact fluorescent lights, which typically offer 560 lumens at 10 W, can be purchased for a few dollars and should last, or so the packaging claims, up to eight years. For the same savings in electricity as you'd get with a single LED bulb, you would need to purchase two or three additional CFL bulbs over the next 25 years. Luckily they are available in packs of two or four.

Light bulbs are a commodity item, no matter how long they last. For all the claims of CFL longevity, I have yet to see them reach their expected lifetime. Usually the point of CFL failure is the electronics in the neck, and the same will likely hold true for LED bulbs.

With CFLs, however, we have traded energy consumption for mercury contamination. The attraction of LED bulbs is twofold: They are instant-on, and they are mercury free. The toxicity of rare earths is low, and very little of the material is used in the bulbs anyway.

Over time, LED bulbs will drop in price and will provide a cleaner, safer alternative to CFLs—presumably with a longer life expectancy as well. We can also expect new features; the door is fully open on that front. ■

LED Lighting

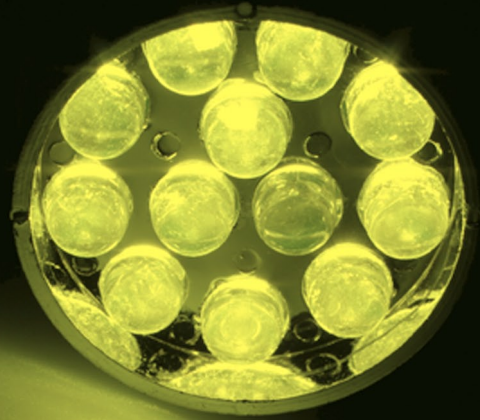

EE Times Europe LED Lighting addresses the rapid breakthrough of LED technology in every field where lighting solutions are required, from display backlighting in Monitors and TVs to automotive lights and home as well as industrial lighting. Products and technologies covered include LEDs, OLEDs, drivers, LED modules, lamps, optics... The target audience comprises both the engineers and the project managers involved in the design and implementation of LED Lighting solutions.

<http://www.ledlighting-eetimes.com>

EE Times
europe
LED Lighting

Medium voltage capacitor discharge resistors in power factor correction

By Martin Birkett

POWER FACTOR CORRECTION is a very popular and well established technique for reducing the overall energy consumption of electrical systems especially power lines, transformers, motors and other high inductive loads. In addition to reducing the energy costs and the carbon footprint, this technique reduces voltage drops, increases the service life by reducing heating and reduces losses through the Joule effect.

The most common and simplest method of power factor correction is to install compensating capacitors on the network close to the load. These capacitors need to be discharged when the power is turned off if they are not to become a safety hazard. New ranges of high voltage discharge resistors are being introduced for this purpose, which not only can handle the high levels of continuous power associated with this application, but also offer excellent short term overload performance in the event of fault conditions.

Medium voltage capacitors for power factor correction

Medium voltage capacitors typically operate at voltages in the range 5kV to 25kV and are constructed from a set of capacitor elements, each with its own fuse, wired in series and parallel groups and fitted inside a dielectric fluid filled metal enclosure with terminals on top.

One of the most important aspects of the capacitor design is the provision of a quick and safe discharge when the electricity is turned off. The capacitors can hold large charges, which, if left to self-discharge, allow dangerous voltages to remain for long periods of time presenting potential safety hazards for service personnel.

The discharge of 0.25J of stored energy to the human body can provide a heavy shock and 10J can be fatal. Therefore one of the most critical components of the capacitor banks is the high voltage discharge resistor

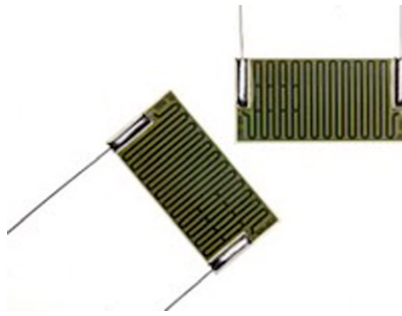

which reduces the residual voltage of the capacitor to a safe working level at turn off.

Medium voltage capacitor discharge resistor requirements

In addition to providing a quick and safe discharge of the capacitor there are several other important requirements to consider when choosing a suitable resistor for this application.

Firstly as the resistor is enclosed in the capacitor housing it is not practical to switch it in to the circuit for discharge. It must be permanently connected and therefore be able to operate continuously at the rated power for the lifetime of the capacitor. Moreover the resistor must be able to handle high voltage overloads up to 25kV during fault conditions, which, due to the relatively low resistance values required in this application (100K to 10MΩ) can be in excess of 150W per resistor. Therefore the device must be able to handle a combination of high voltage and high power.

Secondly as the capacitor housing is completely filled with dielectric fluid the resistor must be chemically compatible with it and not cause any pollution which could adjust the value of the capacitor. Finally as the resistor will normally be hand soldered to the capacitor electrodes and be immersed in the dielectric fluid its terminations need to be very robust to withstand any vibrations during the life of the capacitor.

Case study

To help in finding a viable solution to these requirements the applications team at TT electronics were approached by one of

the market leaders in the development and manufacture of medium voltage capacitors. TT electronics had many years experience of developing high voltage and high power resistors, but not usually with a combination of both, especially on a small planar footprint. Add to this the requirements for chemically compatible materials and robust terminations and the design was beginning to become quite challenging.

High voltage resistors are typically made with high resistivity inks which have excellent voltage handling capabilities and are printed in long meandering patterns in order to reduce the voltage stress. Because the discharge resistors were relatively low values, it was required to manufacture them using low resistivity inks with reduced voltage handling capabilities. The resistor pattern was then optimised to give maximum length to improve voltage handling without jeopardising creepage and clearance distances.

The overload power handling capabilities were optimised by using a high alumina substrate of increased thickness to dissipate the heat into the capacitors dielectric fluid. Once the resistor design was finalised, a method of trimming it to target value was required. Because of the large voltage gradient across adjacent limbs of the resistor pattern the position and cut width of the laser trim links needed to be optimised to reduce the voltage trying to arc across the cut during overload conditions. To achieve this an expanding box cut method was used, which utilises the momentum of the laser to achieve maximum cut width in minimum time.

After trimming the resistor was then protected with a special screen printed material. For this function it was required to use a high temperature firing glaze as low temperature curing materials were found to cause pollution of the capacitors dielectric. This high temperature in turn caused problems with shifts in resistor value during firing

Martin Birkett is Senior Applications Engineer at TT electronics Welwyn Components - www.welwyn-tt.com

which had to be compensated for. Another issue with the glaze was its insulation resistance during overload conditions. As the glaze has a large negative TCR its insulation resistance can decrease when the resistor heats up and create a path for the high voltage to arc. It was therefore important to select a glaze with high insulation resistance and to ensure that no air was trapped in it during processing.

Finally to increase the strength of the terminations the solder pad area was increased and a larger diameter lead wire was used. This also presented an additional problem of reducing the remaining substrate area available to fit the resistor pattern in.

Conclusion

Power factor correction is an excellent and low cost way of reducing energy costs and achieving a range of other worthwhile design benefits. The discharge resistor is by no means a costly element in the context of the overall design, and it is well worth specifying a component that fully supports the envisaged continuous and overload powers, is able to tolerate the environmental conditions and has a sufficiently long service life. Make the right design choice at the outset, and the discharge resistor can become a 'fit and forget' component. ■

“Conflict-free” tantalum

By Jean-Pierre Joosting

AVX CORPORATION, IN PARTNERSHIP with a leading producer of communications technology, has developed the “Solutions for Hope Project,” which is a pilot program established to demonstrate a process to deliver conflict-free tantalum material from the Democratic Republic of the Congo (DRC) under the Organization for Economic Cooperation and Development (OECD) guidelines.

The process' basis is a “closed pipe” principle in which tantalite ore mined from a single site within the Katanga Province of the DRC is traced along its secure closed supply chain to the end customer's equipment in the form of tantalum capacitors supplied by AVX.

AVX will buy the ore from the DRC regional government licensed mine area concession holder at the current market price as published in Metal Pages and transport the ore to the smelter who is a participant in the EICC and GeSI Conflict-Free Smelter (CFS) program. The smelter will convert the ore to capacitor grade powder and wire which will be shipped to AVX, who will manufacture the capacitors and ship them to participating customers for incorporation into end market products.

By minimising the steps and companies involved, we will ensure a validated “closed pipe” system and that the value of the DRC raw materials are not diluted and remain in the DRC for the benefit of the local peoples through the concession holders' commitment to fund social services.

This program provides hope to the small artisanal miners and communities who rely on this work to support them and their families. These miners are suffering from the unintended consequences of a de facto embargo within the non-conflicted regions of Katanga as a result of the Dodd-Frank Act in the USA.

For further information, inquire at - conflict.free@eur.avx.com ■



Superior Solutions for Communications



- Miniaturized SAW filters for all systems
- LTCC modules for cellular multiband and WLAN
- Multilayer chip band pass filters
- Application-specific EMI/ESD filter modules
- Interface transformers, supply transformers and chokes for DSL applications and base stations
- Thin-film common-mode filters for high-speed signal lines
- Common-mode filters for audio lines
- Multilayer chip inductors for high-frequency circuits and modules
- CeraDiode® 0201 and 0402 for ESD protection
- Surge arresters and varistors for all systems
- NTC thermistors for temperature management
- PTC thermistors for line protection
- Multilayer ceramic chip capacitors for long service life
- EMC filter modules for base stations

www.tdk-epc.com

TDK-EPC Corporation

SPS / IPC / DRIVES • Nuremberg, Germany
November 22 to 24, 2011 • Hall 4, Stand 160



Gate-drive transformers

switch within a range of 150 kHz to several MHz

TDK-EPC has developed a new series of Epcos EP5 SMT pulse transformers. They are used to couple gate-drive circuits to MOSFETs and IGBTs operating at switching frequencies within a range of 150 kHz to several MHz. These transformers are available with a wide range of turns ratios, polarities and outputs. Relying on miniaturized EP5 cores, these transformers measure only 8.1x6.7x5.4mm. The size reduction of the transformers results in significant space savings on circuit boards. Thanks to a special winding technology, parasitic capacitance between windings are only 25 to 95 pF, depending on the type.

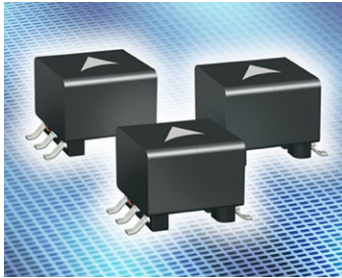

Stray inductances are likewise low. They range between 0.9 and 2.5 μ H. Short-term dielectric strength is tested to 1500 V DC for all types of the B82804A series. These components are designed for ambient temperatures of up to 85 °C and operating temperatures of up to 125 °C. Their terminal configuration and pin assignment correspond to the industry standard. The main applications of these new transformers are half- and full-bridge converters as well as in frequency converters or inverters.

TDK Corporation

www.epcos.com

High-current inductor in 3232 case

3.0mm thin for values up to 10.0 μ H

Vishay Intertechnology's new IHLP low-profile, high-current inductor in the 3232 case size comes with an ultra-low profile of 3.0 mm. The compact IHLP-3232CZ-01 offers high efficiency with maximum DCR down to 1.61 m Ω and a wide range of standard inductance values from 0.22 μ H through 10.0 μ H. With a frequency range up to 5 MHz, the new IHLP-3232CZ-01 serves as a high-performing, space- and power-saving solution for voltage regulator module (VRM) and dc-to-dc converter applications in end products. The device offers an inductance range from 0.22 μ H to 10.0 μ H, a saturation current range from



8.2A up to 43.0A, a heat rating current range from 4.7A to 32.0A, and maximum DCR from 1.61 m Ω to 71.20 m Ω . The new inductor handles high transient current spikes without hard

saturation. Packaged in an RoHS-compliant, 100% lead (Pb)-free shielded, composite construction that reduces buzz noise to ultra-low levels, the device is specified for an operating temperature range of -55 to +125 °C, with high resistance to thermal shock, moisture, mechanical shock, and vibration.

Vishay Intertechnology

www.vishay.com

Toroidal SMT power inductor

7.8x5.2x1.8mm unit takes up to 3A

Murata Power Solutions announced the 8300 series of toroidal surface mount power inductors in a 7.8x5.2x1.8 mm profile. The toroidal core of the 8300 series ensures that the magnetic flux is confined to the core. As a result stray fields are almost totally eliminated, accounting for the exceptional EMI characteristics of the series. With a device dependent maximum DC current of 3.0A, inductors are available from

0.42 to 100 μ H. DC resistance ranges from 24 m Ω up to 1320 m Ω across the range. The 8300 series has an operating temperature range from -40 to +85 °C. Supplied in tape and reel for high volume automated surface mount assembly, the maximum reflow solder temperature is +260 °C as required by J-STD-020D.



Murata Power Solutions

www.murata-ps.com

Multilayer chip capacitors

up to 220nF of capacitance

The X7R dielectric MLCCs from Syfer Technology are now available with a defined capacitance variation under applied DC voltage, across the full operating temperature range. Derating or using a higher voltage rating can reduce the capacitance drop but where an application requires more stable performance with minimal voltage derating then these parts are particularly suitable.

The advantage of devices with a clearly specified limit for the fluctuation is that they give designers the data they need to make an informed choice for their application. Syfer's TCC/VCC range of X7R MLCCs is available in two versions. The "B" code dielectric conforms to MIL STD BX dielectric and IECQ-CECC 2X1 standards, while the "R" code dielectric (conforms to MIL STD BZ dielectric and IECQ-CECC 2C1 standards.) The 2X1 (BX) devices, for example, are the most voltage stable of the X7R

versions, at +15 to -25% capacitance change with full rated DC voltage applied across the full temperature range. The 2C1 (BZ) offer +20 to -30% capacitance charge.

The 2X1 (BX) range includes devices rated at 50V, 100V and 200V, and with capacitance ranges from 100pF to 4.7nF (50V, 0603), through 2.7nF to 180nF (50V, 1808) up to 15nF to 1 μ F (50V, 2225). Comparable devices

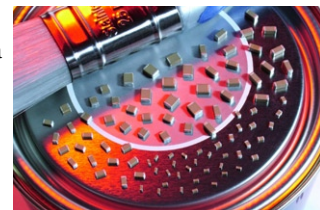

in the 2C1 (BZ) range are 100pF to 5.6nF (50V, 0603), 2.7nF to 220nF (50V 1808), and 15nF to 1.5 μ F (50V, 2225). The devices

are available with FlexiCap terminations using Syfer's proprietary flexible termination material, which make them considerably more resistant to damage through bending or flexing, and when under stress and temperature cycling extremes. Alternative terminations are also available.

Syfer Technology

www.syfer.com

Ceramic COG capacitors

0402 case size for operation up to 200°C

Passive component manufacturer Kemet has announced what it claims to be the industry's first Multilayer Ceramic Capacitor (MLCC) in an EIA 0402 case size capable of reliable performance in environments up to 200°C. The 200°C series features a robust and proprietary base metal dielectric system that offers downsizing opportunities for CoG capacitors. The new devices offer replacement opportunities for existing X7R/BX/BR technologies. Typical applications include critical timing, tuning, circuits requiring low loss, circuits with pulse, high current, decoupling, bypass, filtering, transient voltage suppression, blocking and energy storage for use in extreme environments. High temperature environments are commonly present in down-hole exploration equipment, aerospace engine compartments and geophysical probes.

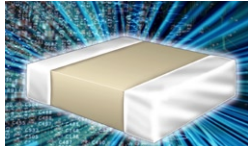

offers downsizing opportunities for CoG capacitors. The new devices offer replacement opportunities for existing X7R/BX/BR technologies.

Kemet

www.kemet.com

SMT dielectric filters

cut costs, board-space and lead-times

ACAL Technology announced a new range of competitively-priced, compact surface-mount dielectric filters for GPS and industrial applications. Advanced Crystal Technology's (ACT) SE series of dielectric filters are available on a short lead-time of 3 to 4 weeks, compared to a standard industry lead-time of 8 weeks.

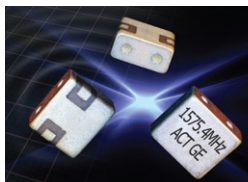

The compact filters are housed in a 5.0x5.6x2.8mm package and operate at a frequency

of 1575.4MHz with a bandwidth of 2MHz or 10MHz. To further accelerate the transition through design and prototyping to full production, ACAL provides specialist support during development, using its UK in-house testing services for frequency-control devices. These services include the testing of crystal and oscillator parameters and characteristics, shock and solderability testing, as well as high-temperature storage.

ACAL Technology

www.acaltechnology.com

Panel potentiometer

IP68 sealed for deep submersion

Vishay Intertechnology has introduced a submersible cermet panel potentiometer that is fully IP68 sealed against deep sea water. Featuring a stainless steel shaft and bushing, the P13SM is designed for applications where electrical parameters need to be set with an immersed potentiometer in deep sea salt water conditions up to 30m. The device achieves corrosion resistance times of up to 960 hours in a salt spray test. The P13SM offers a high power rating to 1.5W at +70°C and tight TCR of ± 75 ppm/°C typical. The device's cermet element provides better stability than carbon elements, and offers greater reliability and robustness. The Sfernice potentiometer is optimized for use as a voltage divider operator interface. The potentiometer comes in 3.17 and 6mm shaft diameters, and multiple shaft lengths.



deep sea salt water conditions up to 30m. The device achieves corrosion resistance times

of up to 960 hours in a salt spray test. The P13SM offers a high power rating to 1.5W at +70°C and tight TCR of ± 75 ppm/°C typical. The device's cermet element provides better stability than carbon elements, and offers greater reliability and robustness. The Sfernice potentiometer is optimized for use as a voltage divider operator interface. The potentiometer comes in 3.17 and 6mm shaft diameters, and multiple shaft lengths.

Vishay Intertechnology

www.vishay.com

Land-grid array capacitors

to include 0805 2-terminal case size

AVX has enhanced its land-grid array (LGA) capacitor product offering to include a low inductance 2-terminal 0805 package for advanced decoupling applications. Designated the LGC Series, the advanced capacitor is available with 100% tin and tin lead terminations to provide high-frequency performance similar to an 8-terminal interdigitated capacitor (IDC), making it suitable for design engineers in both commercial and military and aerospace applications.

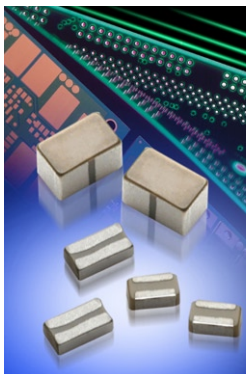

The LGC Decoupling Capacitor Series provides capacitance values of 1.0µF at 6.3V and 2.2µF at 4V in an X5R dielectric formation across an operating temperature range of -55°C to +85°C.

AVX

www.avx.com

Perfection & competence

SMD-connectors from

fischer

elektronik

- high temperature durable plastic insulation body (all suitable for reflow-solder process)
- RoHS compliant versions
- lead free tin plating of the contacts

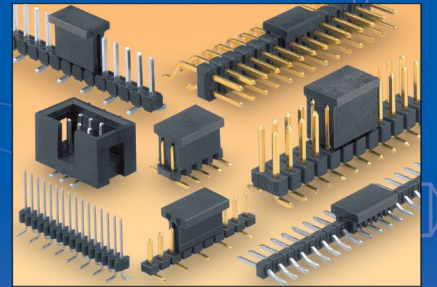

Male headers in SMD technique
grid spacing of 2,54/2,0/1,27 mm, with pick-and-place pad, tube magazine, tape and reel (partially)

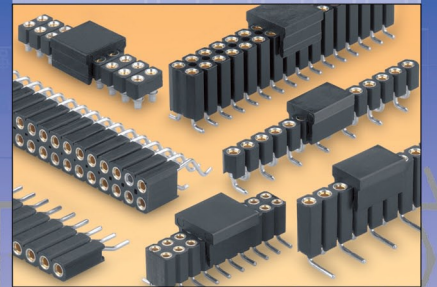

Female headers in SMD technique
grid spacing of 2,54/2,0/1,27 mm, with pick-and-place pad, tube magazine, tape and reel (partially)

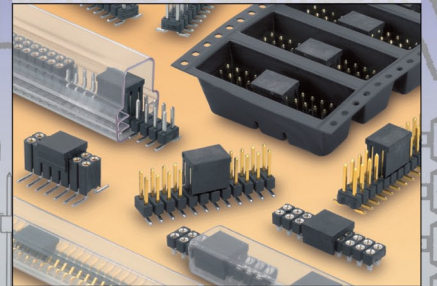

Packagings for automatic assembly of the SMD headers
tape and reel, tube magazine

P. O. Box 1590 D-58465 Lüdenscheid
Nottebohmstraße 28 D-58511 Lüdenscheid
Tel. +49 23 51 4 35-0 Fax +49 23 51 4 57 54
info@fischerelektronik.de
www.fischerelektronik.de

Cases
Heatsinks
Connectors

RFID transceiver chip

eight selectable power modes from 1µA to 120mA

Claimed to be the industry's lowest-power contactless short-range communication transceiver, TI says the TRF7970A extends battery life up to 2 times longer than competitive products, as it provides eight selectable power modes ranging from $1\ \mu\text{A}$ in power-down mode to 120 mA in full-power mode.

The transceiver comes with configuration software and royalty-free stacks that are compatible across a broad range of ultra-low-power MSP microcontrollers. Additionally, developers are able to directly access all control registers, allowing for fine-tuning of various parameters for the highest performance in every application.

The new TRF7970A builds on TI's platform of RFID products by supporting peer-to-peer communication and card emulation

in addition to reader/writer capability while maintaining pin-for-pin compatibility with the TRF7960.

Peer-to-peer communication continues to increase in popularity in applications including medical equipment, secure pairing and payments. This allows users to more easily take advantage of continuously evolving features and apps.

For example, NFC devices can configure Wi-Fi and Bluetooth technology sessions between devices without consumer interaction, share and interact with feature- and content-rich data such as coupons at point of sale, and allow consumer devices to easily exchange files and contacts.

Texas Instruments

www.ti.com

Piezoelectric accelerometer

miniature and lightweight, 10mV/g sensitivity

The Endevco model 2250A adhesive mounted piezoelectric accelerometer from Meggitt Sensing Systems comes with integral electronics, designed to support high-reliability vibration measurements of mini-structures and smaller objects within aerospace, automotive, electronic

product and product life cycle testing applications. Offered with a sensitivity of 10 mV/g, the unit features high resonance frequency and wide bandwidth, with a lightweight (0.4g) design that effectively eliminates mass loading effects.

The accelerometer incorporates Meggitt's own Piezite type P-8 crystal element, operating in annular shear mode, which

exhibits excellent output sensitivity stability over time. The accelerometer also incorporates an internal hybrid signal conditioner within a two-wire system which transmits its low-impedance voltage output through the same cable that supplies the constant current power.

Signal ground is isolated from the mounting surface by a ceramic mounting base. A field-replaceable miniature coaxial cable is supplied with the 2250A-10, as well as a special tool to ensure proper removal of the accelerometer (model 31275) from its adhesive mounting surface.

Meggitt Sensing Systems

www.meggittsensing.com



FPGA embedded intelligent IP

enables ultra-fast Flash programming

In cooperation with Testonica, Goepel electronic developed the ChipVORX model library series, structured modularly as intelligent IP for FPGA accelerated in-system programming (ISP) of Flash components. The models enable the ultra-fast in-system programming of every kind of Flash components at full workflow automation.

Fully integrated, the ChipVORX IP enables the automatic recognition of the structural connections between the Flash target and the FPGA, as well as the succeeding script file generation. The programming is based on a standardised IEEE 1149.1 TAP (Test Access Port) and can be executed on each run time station without further options. Thereby, Gang applications are supported. The ChipVORX IP is independent of the target to

be programmed, so there are no restrictions on the Flash type. In addition to serial Flash, parallel NOR and NAND Flash incl. bad block handling is supported.

In practice, the ChipVORX IP achieves drastic accelerations for bigger FPGA types compared to standard Boundary Scan programming procedures. Whilst typical values for parallel Flash are between 10 and 15 times, the factor for serial Flash achieves a size of 100 times and even higher. The acceleration is only limited by the Flash internal programming speed.

Currently, the ChipVORX models for Flash programming are available for all Altera and Xilinx FPGA families, additional ones are under development.

Goepel Electronic

www.goepel.com

V850 MCU platform

for Continua-certified blood glucose meter agent

Renesas Electronics launched a Continua demonstration platform based on the its V850 energy-efficient microcontroller (MCU) with certified Continua Blood Glucose agent software. Implementing a blood glucose meter as defined by the Continua Health Alliance, the platform shows how the V850 MCUs implement complete software functionality at a level of power efficiency that ensures long battery life.

The energy-efficient V850 MCUs, at about 350uA/DMIPS with up to 1 megabyte (MB) of Flash memory and integrated USB function support, make it possible to handle the added software load without sacrificing the long battery life that end users have come to expect.

The Renesas Electronics V850 Continua demonstration platform implements a set of

guidelines for blood glucose meters developed by the Continua Health Alliance. Alliance guidelines use key industry standards to ensure an end-to-end architecture from personal medical devices to hospital information systems. One such standard is ISO/IEEE 11073, which defines a medical device, the measurements that it makes, and a protocol for communicating the measurement data. While the Continua demonstration platform uses USB, the V850ES/Jx3-L MCUs can also support Bluetooth and ZigBee functionality. An optional persistent metric store (PM Store) supports off-line storage of measurement data until the device can connect to a network and automatically send the data.

Renesas Electronics

www.am.renesas.com

High-speed switching MOSFETs

fit within 3.3x3.3mm TSON Advance package

Toshiba Electronics Europe (TEE) has extended its 30V power MOSFETs based on its 7th generation, high-speed U MOS VII-H semiconductor process.

The latest additions to the TPCx family of low withstand voltage power MOSFETs comprises nine devices in SOP-8 and the new TSON Advance package formats. The latter bridges the gap between industrial standard SOT23 and SOP8 package formats - at just 3.3x3.3 mm this package format delivers a 64% smaller footprint than a SOP-8 device with an equivalent power rating. The U MOS VII-H low-voltage trench structure allows the new MOSFETs to deliver a combination of low on resistance and high-speed switching character-



istics. In addition a low internal gate resistance and a low C_{gd}/C_{gs} gate capacitance ratio helps to prevent the possibility of self turn-on.

All of the new MOSFETs have a maximum V_{DS} rating of 30 V and a maximum V_{GS} rating of ± 20 V. Typical $R_{DS(ON)}$ values ($V_{GS} = 10$ V) range from 20 m Ω down to just 6.0m Ω depending on the device chosen. TPC806x-H and TPC822x-H devices are supplied in SOP-8 and dual Chip SOP-8 packages respectively. TPCC806x-H parts in the TSON advanced package achieve a power dissipation of 1.9 W, due to a metal base plate.

Toshiba Electronics Europe

www.toshiba-components.com

Gyroscopic evaluation platforms

based on Epson's QMEMS quartz technology

Seiko Epson Corporation announced the development of two new series of sensing platforms, based on the company's QMEMS and semiconductor technologies. The evaluation tools include the E Series, consisting of two multifunction sensor evaluation units, and the M Series compact and specialized evaluation modules. The sensing platforms combine Epson's QMEMS quartz gyroscopic (angular rate) sensors with the company's hardware (a unit or module) that processes and digitizes sensor data with software that displays and stores sensor data sent to a PC via one of the many wired, wireless and other interface options. The multifunction sensor evaluation units have a six-axis sensor, which consists of three Epson gyroscopes that provide high accuracy and stability

($\pm 1,000$ °/s) on three axes and a triaxial accelerometer with a dynamic range of ± 6 G, a triaxial geomagnetic sensor, and a pressure sensor. These evaluation units are available with either a ZigBee6 or a USB interface for easy connection to a PC. The M Series consists of more compact and even easier-to-use sensor evaluation modules with specialized sensor functions. There are two models in the M Series: the S7U4E002002, a highly accurate motion sensor with six degrees of freedom, and the S7U4E002003, a position sensor with a GPS receiver. Specialized for a single function and sporting a compact design, each of these modules can easily be built into portable, hand-held evaluation equipment.

Seiko Epson Corporation

www.epson-electronics.de

Power Management



EETimes Europe Power Management focuses on the variety of day-to-day design, news, and product issues that face engineers involved in the design or implementation of power management technologies including power supplies, power components, batteries, fuel cells, solar cells and UPS systems. The target audience comprises both the engineers and the project managers involved in the design and implementation of power management solutions. The goal is to provide a mix of technical information that helps make the power management design process simpler to implement and faster to achieve.

<http://www.power-eetimes.com>

EETimes
europe
POWER MANAGEMENT

Intelligent power switch

features current sensing for automotive use

International Rectifier has introduced the AUIR331x family of high-side intelligent power switch (IPS) devices with accurate current-sensing and built-in protection circuits for automotive applications. The new IPS devices enhance reliability in intelligent glow-plug controls, auxiliary positive temperature coefficient (PTC) heaters, engine cooling fan drivers and interior fan controllers. The current-sensing accuracy, particularly at low current, enables precise monitoring of load current in order to provide additional data to the microcontroller for diagnostic applications. Typical examples include open-load detection, early warning of overload



conditions or stall motor condition. In addition, the AUIR3316S provides a slow-switching version of the AUIR3313S, which helps minimize noise in EMI-sensitive automotive applications.

In addition to current-sense feedback, the AUIR331x family of devices integrate over-temperature and over-current shutdown to offer capability to operate repetitively under short circuit conditions according to the latest AEC Q100-012 standard. In many applications, additional protection devices such as fuses can be eliminated.

International Rectifier

www.irf.com

MEMS multi-sensor module

offers six degrees of freedom

STMicroelectronics has expanded its portfolio with a new device that combines three-axis sensing of both linear and angular motion. The LSM330DL multi-sensor module detects acceleration up to 16g and angular

and mechanical stability. Addressing energy efficiency on chip and at the system level, the motion-sensing module includes power-down and sleep modes and an embedded FIFO (first-in first-out) memory block, which

removes the need for continuous communication between the module and the host processor. The device can operate with any supply voltage in the range of 2.4 to 3.6 V. The device is pin-to-pin and software-

compatible with the recently announced five-degrees-of-freedom LSM320DL module, so customers can easily 'hot swap' and protect their investment in application development.

STMicroelectronics

www.st.com



rate up to 2,000 dps along the pitch, roll and yaw axes. The integration of a 3-axis digital accelerometer with a 3-axis digital gyroscope in a single device increases system robustness and the advanced design of the mechanical sensing structure guarantees thermal

Industrial networking kits

two units to win based on Altera's Cyclone IV E FPGA



Altera has expanded its industrial networking partner program to include IP and Terasic's industrial networking kit (INK) featuring Altera's Cyclone IV E FPGA. The kit is a full-featured hardware platform based on the Terasic DE2-115 FPGA board with dual

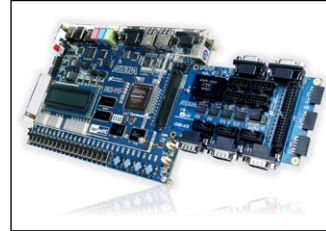

10/100/1000 Ethernet, 128-MB SDRAM, 8-MB flash memory, 4-MB SRAM, security EEPROM, HSMC connector, GPIOs, toggle switches, and status LEDs along with USB, audio, and video capabilities. The INK features a Cyclone IV E (EP4CE115F29) FPGA and supports most industrial Ethernet and fieldbus networking standards, enabling all IP vendors to support the latest

generation of low-cost FPGAs. Altera FPGAs are programmable and allow engineers to evaluate and develop multiple industrial Ethernet protocol standards on a single device, such as a Cyclone IV device. The kits are suit-

able for industrial automation and process control applications for servo/drive/motion-control equipment, sensors, programmable-logic controllers, machine vision, and video surveillance equipment. This month, Altera is giving away two INK kits, worth 600 Euros each, for EETimes Europe's readers to win.

Altera

Check the reader offer online at www.electronics-eetimes.com
www.altera.com

Dual switch flyback solution

alternative to LLC, single QR flyback topologies

Fairchild Semiconductor is offering a dual switch flyback solution incorporating mWSaver technology to meet these challenges faced by designers of power supplies for All-In-One (AIO) applications. Fairchild's AIO solution is perfectly suited for applications from

consumption at no/light load, enabling designs to meet 2013 ErP standard without the additional circuitry LLC solutions require. Incorporating mWSaver

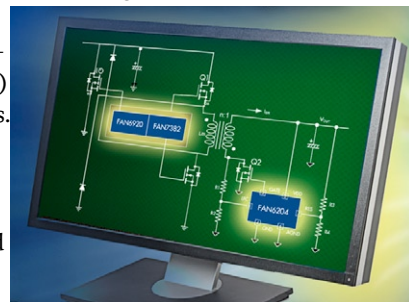

75W to 230 W. It consists of the FAN6920MR integrated critical mode PFC and Quasi-resonant Current Mode PWM controller, the FAN7382 gate driver, in tandem with the FAN6204 secondary synchronous rectifier controller for flyback topology and forward freewheeling rectification. Combined, these devices provide best-in-class power

technology, these devices additionally offer the lowest standby power input for AIO solutions. Quasi-resonant control reduces snubber and leakage inductance losses, while improving thermal issues. The device also lowers the Vds of the SR MOSFET to provide improved efficiency, and allows for smaller board size. Built-in two-level PFC output improves low line efficiency.

Fairchild Semiconductor

www.fairchildsemi.com

First 25nm DRAMs

for PC and server applications

Japan's Elpida Memory claimed to be the first memory supplier to sample DRAMs with circuit line widths of 25 nanometers. The 25-nm devices are DDR3 [double data rate 3] SDRAM with a memory capacity of 2-gigabits. A 25-nm 4-gigabit DDR3 SDRAM is expected to become commercially available by the end of 2011.

The 25-nm products will be used for PC and server applications, Elpida said. The process will also be used to develop applications for Elpida's mobile RAM for use in various kinds of mobile devices, starting with the growth areas of smart phones and tablet PCs, the company said.

Special features of the 25nm SDRAM include lower current usage—roughly 15 percent less during operation, 20 percent less when on standby—compared with Elpida's current advanced process 30-nm-generation products and one of the highest data transfer rates in the industry, according to Elpida.

Elpida

www.elpida.com

Atmel targets M2M

with latest SAM devices

Five new additions to its ARM926-based MCU range offer an integrated soft modem to reduce BoM, as well as support for DDR2 memory. While the soft modem technology is described as 'unique' to the new SAM9 devices, another 'value add' feature is the integration of an LCD controller which features hardware acceleration and a graphics



overlay controller, delivering alpha blending, image scaling, rotating and colour space

conversion. The devices also integrate better support for external memory and are able to interface to up to 256Mbyte of DRAM and 'many Gbytes' of DDR2. Support for DDR2 is through a 24bit ECC and is seen as supporting the industry transition from SDRAM to DDR2, allowing larger density memories using single and multilevel cell technology. The core voltage of the devices is 1V and consume as little as 110mW at 400MHz.

Atmel

www.atmel.com

'Unbreakable' security IP

now on Flash-based cSoCs

Microsemi is now offering Intrinsic-ID's Quiddikey security intellectual property (IP) on its flash-based devices and development boards, which includes the company's patented physical unclonable function (PUF) technology, enabling an added level of security in secure government applications as well as in commercial markets including the financial, energy, automotive and mobile industries. The IP, which is available on the SmartFusion customizable system-on-chip (cSoC), as well as ProASIC3, IGLOO and Fusion FPGAs, enables more secure products with simpler key management requirements. Security solutions for embedded applications rely on a secret key to guard secure data. Intrinsic-ID's PUF technology extracts a unique secret key directly from the cSoC and FPGA's silicon hardware, as opposed to other solutions that require loading an externally generated key in on-chip non-volatile or battery-backed memory.

Microsemi

www.microsemi.com

Bike batteries

based on lithium iron phosphate chemistry

BMZ Batterien-Montage-Zentrum has introduced the LBP5500 "Lithium Bike Power" battery which weighs 900 grams. The battery, which is specifically designed for powerful motorbikes and quads, has small dimensions of only 95x80x80mm and a rated capacity / voltage of 5500 mAh / 13.2 V.

The LBP5500 battery has a maximum



impulse discharge current of 350 A and a maximum continuous discharge current of 300 A. Thanks to state-of-the-art lithium iron phosphate (LiFePO4)

technology, the safe LBP5500 battery is well suited for use in powerful sports vehicles with 2- or 4-cylinder motors up to 1500 cc capacity. The LBP5500 battery can be fully charged within 45 minutes at a charge current of 7.5 A. For 90 percent of the rated capacity, 15 minutes at a charge current of 20 amps is sufficient.

BMZ Batterien-Montage-Zentrum

www.bmz-gmbh.de

PICO

SURFACEMOUNT
(and thru-hole)
Transformers
& Inductors

Size
does
matter!

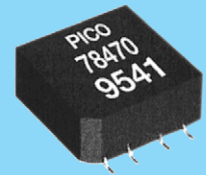

from
low-
profile

.19"ht.

- Audio Transformers
- Pulse Transformers
- DC-DC Converter Transformers
- MultiPlex Data Bus Transformers
- Power & EMI Inductors



See Pico's full Catalog immediately
www.picoelectronics.com

FREE PICO Catalog
Fax 914-738-8225
PICO Electronics, Inc.

143 Sparks Ave. Pelham, N.Y. 10803
E Mail: info@picoelectronics.com

Pico Representatives

Germany

ELBV/Electronische Bauelemente Vertrieb
E-mail: info@elbv.de
Phone: 0049 89 4602852
Fax: 0049 89 46205442

England

Ginsbury Electronics Ltd.
E-mail: rbennett@ginsbury.co.uk
Phone: 0044 1634 298900
Fax: 0044 1634 290904

Frequency hopping filters

mitigate interference issues

Trilithic has introduced a series of frequency hopping filters that enable users to address interference issues in environments crowded with RF signals.

The VTF series of frequency hopping filters is designed to help mitigate the issues that commonly occur in shipboard,

airborne and ground vehicle applications with an RF crowded environment.

The VTF series filters offer drop-in second source capability for existing programs, while



being versatile enough for new programs. They are rugged and durable, and work across multiple frequency ranges and bandwidths. Several frequency

ranges and percentage bandwidths are currently available, and Trilithic plans to introduce higher power designs, extended frequency ranges,

various connector and mounting options, and multiple control options in the near future.

Trilithic

www.trilithic.com

ZigBee Smart Energy 1.1 test suite

for full product conformance testing

European test house, TRaC, has concluded a comprehensive product test programme for Danish manufacturer Develco Products within days of the release of the latest version of the ZigBee wireless data standard for Smart Energy products.

The ZigBee Alliance formally made available version 1.1 of ZigBee Smart Energy – the only widely available Advanced Metering Infrastructure standard. The standard is based on the well-established ZigBee

standard for self-organising (mesh) wireless data networking using the 2.4 GHz band. ZigBee Smart Energy overlays the protocols and services that will be needed to build the metering and control infrastructure for the much-discussed Smart Grid of the future.

The latest, 1.1 version adds a number of key features including dynamic pricing enhancements and over-the-air updates;

all requiring backward-compatibility with certified ZigBee Smart Energy products that conform to version 1.0.

Any of these features and services embodied in Smart Energy products must be fully tested for conformance before the product can be declared as ZigBee SE 1.1-Compliant. TRaC is currently the only test house in Europe

ready and able to carry out this test programme – and one of only a select few sites world-wide. Danish manufacturer Develco Products makes extensive

use of wireless data protocols. As a member of the ZigBee Alliance since its inception, Develco has always ensured rigorous adherence to ZigBee standards in all of its products. Working closely with TRaC over a period of several months, the two companies monitored the Standards process for any late changes.

TRaC

www.tracglobal.com



High-speed bus switch

supports 5-V interfaces

Toshiba Electronics Europe has expanded its family of bus switches with a new device that addresses the data rate and power requirements of high-speed digital applications requiring a 5 V interface.

Typically, the development towards higher speed interfaces goes hand-in-hand with

the reduction of supply and I/O voltages, which is no problem in consumer type of applications.

The new bus switch offers high-speed operation through reduction of capacitance and resistance values while keeping the supply voltage at 5 V, making the device especially attractive for industrial applications.

The TC7MB3257C is a quad SPDT bus switch that operates from a supply voltage between 4.0 V and 5.5 V. In the ON state the switch exhibits a typical terminal capacitance of only

8.5 pF and an ON resistance of 3 Ohm. This results in a 3 dB cut-off frequency of 590 MHz, which represents an improvement compared with previous devices.

The resulting reduction of signal rise and fall times enables support of high data speeds. The 2.7x2.7x0.6mm TC7MB3257C can operate in multiplexing or full isolation mode.

Multiplexing of the active output port is achieved by applying a select signal, while full isolation between input and output can be achieved with the output enable voltage. Additional features of the TC7MB3257C are a maximum quiescent current of only 10 µA, power down protection for all input pins and integrated protection against electrostatic discharge up to 2 kV according to the Human Body Model.

Toshiba Electronics Europe

www.toshiba-components.com



Lead-free aspherical glass lens

1x1mm unit designed for optical communications

Alps Electric has developed the FLGS3 Series aspherical glass lens for optical communication in submarine cables and base stations. The FLGS3 Series lens

has high optical coupling efficiency and is compatible with wide-angle laser diodes, it comes in a 1x1mm profile which the

company says is the industry's smallest. The manufacturer has expanded the effective numerical aperture (NA) to 0.65x0.13 (from 0.5x0.1) while retaining the industry's smallest size.

This raised optical coupling efficiency from 68% to 73%, contributing to lower losses and lower power consumption.

What's more, the FLGS3 Series

lens is made from lead-free glass, achieving compliance with both RoHS 6 and REACH regulations. The lens is compatible with standard optical

communication wavelengths (1260nm to 1625nm) and a visible light option is also available.

Alps Electric

www.alps.com



Automotive electronics

covered between Rutronik and Renesas

Rutronik Elektronische Bauelemente GmbH will now be distributing the entire Renesas product range throughout Europe. Both companies are working together with particular intensity in the automotive sector. "Just like Renesas, Rutronik has its own Automotive Vertical Market Team, made up of product and application specialists, who focus specifically on the automotive market," explains Heiko Zimmermann, Senior Sales Engineer Major Distribution at Renesas Electronics.

"It was this focused approach with the corresponding broad and extensive expertise and the very successful cooperation to date that has led us to select Rutronik as a strategic distribution partner for the key automotive market."

Rutronik is now responsible for Europe-wide distribution of the entire Renesas product range, focusing in particular on the automotive market.

Rutronik Elektronische Bauelemente GmbH

www.rutronik.com

RS Components website

increases focus on e-centric vision

RS Components has revamped its website, going live this month in the UK, to enhance the online experience for its customers. A new intelligent product search feature and superior browsing capability give customers faster and easier access to over 550,000 products. The new website represents the latest step in a plan to put eCommerce firmly at

the heart of the company's business, ensuring that RS customers enjoy the best and most relevant online experience, regardless of location or browsing device. The launch follows extensive research by RS into its customers' use of the website and takes the best examples offered by consumer websites from around the world. The new functionality enables customers to more easily search the products that they want and to access an array of 3D CAD models.

RS Components

www.rswww.com

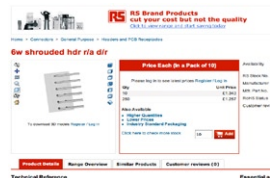

Arrow signs Zenaro

for the whole EMEA region

Arrow Electronics and Zenaro Lighting GmbH have entered into a distribution agreement for the EMEA region. Founded in 2010 and with headquarters in Kamp-Lintfort, Zenaro Lighting GmbH develops LED lighting and lighting systems, power supplies and light engines. The company services numerous markets, such as street lighting, office and industrial lighting, the consumer and lifestyle sector, retrofit solutions, and LED components. Although Zenaro focuses primarily on the European market, it is globally networked through Zenaro Lighting America and Zenaro Lighting Asia. "Arrow has developed a strong team of experts in the lighting segment, along with the corresponding know-how for significant lighting markets," says Hubert Niewerth, general manager of Zenaro Lighting. "We want to use our network to grow globally, and with Arrow as a worldwide distributor, we've now laid an important cornerstone for collaboration in the EMEA region."

Arrow Electronics and Zenaro Lighting GmbH

www.arrow.com

Digi-Key signs Everlight

to bring more LEDs to market

Electronic components distributor Digi-Key Corporation has signed a global distribution agreement with Everlight Electronics, the manufacturer of through-hole and surface mounted LEDs, optical sensors and infrared components, and state-of-the-art lighting fixtures and digital LED displays. "With this agreement, Digi-Key has recognized our customer's strong demand for Everlight products," said Mark Zack, vice president, semiconductor, Digi-Key Corporation. "By offering Everlight's top quality LED and lighting solutions, we are able to meet the design and supply chain needs of the engineering and purchasing communities."

"Our customers expect worldwide availability and support for our products. We are convinced that Digi-key is a strong partner for the broadening of our sales channels."

Digi-Key Corporation

www.digikey.com



PICO

AC-DC Converters
Power Factor Corrected
5-300VDC
Isolated DC Output
Low Cost Industrial

**UP TO
300
WATTS**

Two Units in One
AC1 Series



Universal AC Input
47-400Hz
Input Frequency

- **STANDARD:** 5 to 300 VDC regulated, **ISOLATED** outputs/ Fixed frequency
- **ALL in ONE** compact full brick module, 2.5" x 4.6" x 0.8" Vacuum encapsulated for use in rugged environments
- Lower cost for your Industrial applications
- Maximize your design 300 watt models
- Meets Harmonic Distortion specifications
- .99 Power factor rating at operational levels
- Expanded operating temperatures available -40 & -55C, +85 & 100C base plate
- Custom models available



Pico Representatives

Germany
ELBV/Electronische Bauelemente Vertrieb
E-mail: info@elbv.de
Phone: 0049 89 4602852
Fax: 0049 89 46205442

England
Ginsbury Electronics Ltd.
E-mail: rbennett@ginsbury.co.uk
Phone: 0044 1634 298900
Fax: 0044 1634 290904

www.picoelectronics.com

Send Direct
for free PICO Catalog
E-Mail: info@picoelectronics.com
PICO Electronics, Inc.
143 Sparks Ave, Pelham, NY 10803-1837
Call Toll Free 800-431-1064 • FAX 914-738-8225

The universal IP platform and European IP start-ups to watch

By Rick Clucas

THE DESIGN AUTOMATION CONFERENCE (DAC) has evolved over the years, from something that was a major trade show prior to 2002 to a small focused conference today for the EDA and semiconductor IP industry. Since the exit achieved by Icera recently in the UK, I thought the market might again be buoyed up so I decided to attend this year's DAC which took place in San Diego recently. The role of the DAC conference has evolved – the purpose of tradeshow has changed dramatically because of the Internet, but I still believe they have an important part to play in the overall sales and marketing process. As a visitor I find they are the best way for getting a feel for the current state of an industry, DAC was not to disappoint in this regard.

Twenty years ago when I was technical director for a 3D video games company called Argonaut Software, we had won a contract to develop some 3D games for their soon to be released next generation Super Nintendo Entertainment System, the SNES. This was designed for doing 2D 'Sprite' based games and did not even have a pixel-mapped screen memory, so we suggested developing a 3D graphics chip to go inside the cartridge. To solve this software problem we ended up developing a 16-bit RISC processor with special instructions to help with graphics called the SuperFX chip. This was probably the first example of an application specific instruction-set processor and certainly an early example if not the first of developing a chip to solve a software or system level problem. We prototyped it using an FPGA enabling us to further develop the instruction set and develop the software months before we had real silicon. Over the next few years we further developed these ideas until eventually we had created the ARC, which was the first processor designed to be customized to the needs of the software or system rather

Rick Clucas was founder of configurable RISC processor company ARC International and has held a number of senior roles in the global semiconductor IP industry. He was most recently CEO of 4G soft multi-mode modem company Coresonic.

than the software having to work around the limitations of the hardware that had been created.

Over the last 20 years there have been many start-ups created to offer system level design



“IP providers are going to need to offer much more complete ‘Universal Platforms’”

tools and technologies: some have worked, others have not. Many of these have now been acquired by larger companies like Synopsys and ARM, including the one I started, ARC.

Now at last the industry is pushing the idea of top-down system level design as the way forward rather than ‘noise’ on the fringes of the industry. Today's systems are now complete very complex products in their own right and have moved on dramatically since the SuperFX chip but I think we can all learn a lot from the work we did 20 years ago to make sure we are prepared for the next 20 years.

Here are the lessons the industry should and is taking on board. Software is key: you need to develop this at the same time as you define and develop the hardware, simple hardware changes can make a massive difference

to the software performance. You can't build it all: use off-the-shelf IP blocks for anything that is not your value-add. Make sure your IP provider can support your system level modelling needs.

IP providers are going to need to offer much more complete ‘Universal Platforms’ which act as building blocks for many applications including wireless connectivity, CPU, audio, 2D & 3D graphics as well as hardware for the new generation of human machine interfaces. These blocks are now becoming tick-box items that everybody will need to some degree in their products. No single established IP supplier yet offers all these blocks – Imagination Technologies is probably the closest, followed by ARM, Synopsys (ARC), Tensilica, CEVA and MIPS.

The DAC conference is always good for spotting new start-ups and this year didn't disappoint. I came across three interesting European start-ups. Codasip - www.codasip.com – offers a tool for developing application specific instruction-set processors. Cortus - www.cortus.com – provides a very small and low power 32-bit processor filling the gap left behind by the big processor companies as they target speed. Think Silicon - www.think-silicon.com - has developed 2D and 3D graphics blocks. All three of these companies are worth watching as I feel they are fulfilling needs that often seem to be neglected by the big companies as they move forward. They have all been funded so far without the need for VCs and they now need to move sales and marketing up to the next level to build on their successes so far.

In a curious co-incidence, this year's DAC was taking place at the same time as the video games industry was having its annual event E3 in Los Angeles and Nintendo launched its new Wii U where the controller now incorporates all the items I think need to be in the ‘Universal Platform’. The co-incidence is that on my return to Europe, I bumped into Shigeru Miyamoto; he was creator of the Mario games, and the person we worked with on the SuperFX chip all those years ago. This year, he had just launched the Wii U at E3! ■

LED
professional

**SYMPOSIUM
+EXPO**

LpS 2011

**EARLY BIRD BONUS
SIGN UP NOW!**

www.lps2011.com

LED Lighting Technologies

International Winning Approaches

**27-29 SEPTEMBER 2011
BREGENZ | AUSTRIA**

CONTACT:

LUGER RESEARCH | Faerbergasse 15 | 6850 Dornbirn
T +43 5572 39 44 89 | F +43 5572 39 44 89 90
info@lps2011.com | www.lps2011.com

TRIDONIC
▼ enlightening your ideas

OSRAM
Opto Semiconductors

e:lumix
LED Technologie GmbH

now available on iPad



free iPad App :

<http://itunes.apple.com/be/app/eetimes/id402418329?mt=8>